

Model GP7128-0021

Triplex Ceramic
Plunger Pump
Operating Instructions/
Repair and Service Manual

GP7128 with Teflon Seals & Viton O-Rings

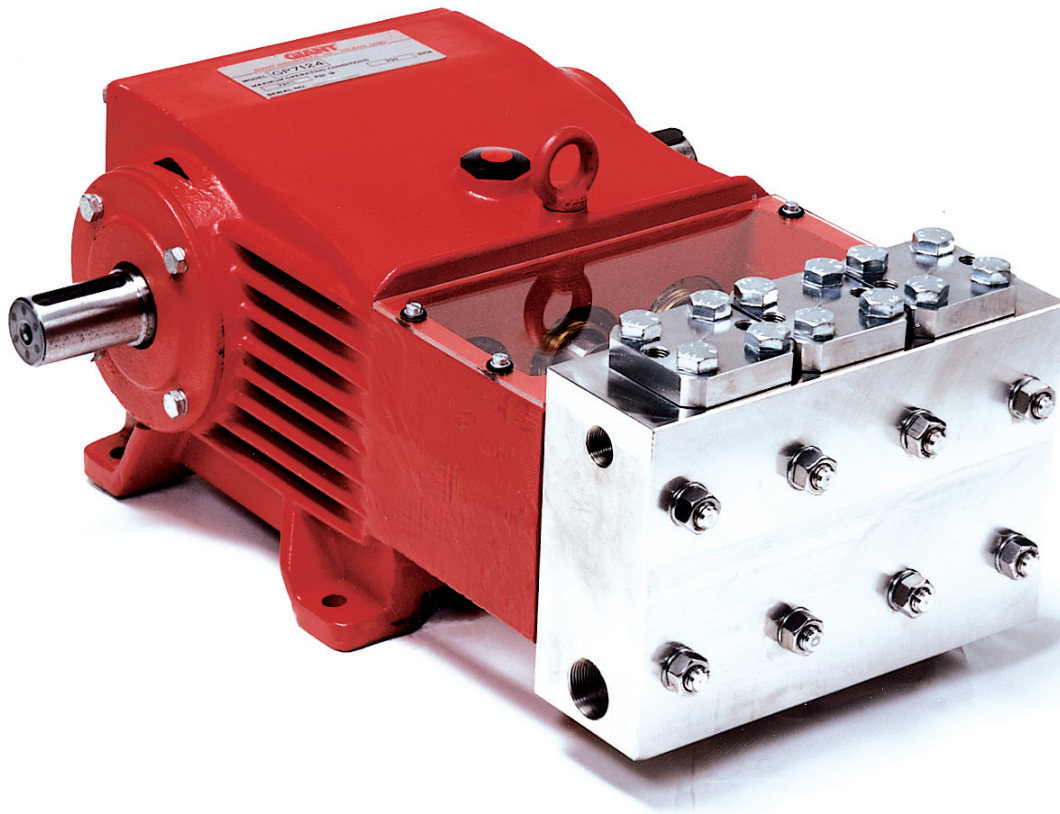

GIANT
Performance Under Pressure

Contents:

Installation Instructions:	page 2
Torque Specifications:	page 2
Pump Specifications:	page 3
Exploded View:	page 4
Parts List/Kits	page 5
Repair and Service:	pages 6-7
Dimensions:	back page
Warranty Information:	back page

INSTALLATION INSTRUCTIONS

Figures given for maximum pressure and maximum speed (rpm) apply to interval operation.

When the pump is used in continual operation and/or with water warmer than 100 °F (40 °C), these values must be reduced by 10%.

Required NPSH refers to water: Specific weight 1kg/dm³, viscosity 1 °E at maximum permissible revolutions.

Operation and Maintenance

Important! If there is a **danger of frost**, the water in the pump and in the pump fittings (particularly the unloader valve) must be emptied. The second discharge port can also be used and the pump run “dry” for 1-2 minutes for this purpose.

Check oil level prior to starting and ensure trouble-free water supply.

Oil: Use only 1.6 gallons (6.0 liters) of ISO VG 220 (e.g. Aral Degol BG220) or SAE 90 gear oil.

We recommend ISO VG 68 (SAE80) gear oil for low ambient temperatures (+41 °F [+5 °C] and less).

Initial change after 50 operating hours and then every 500 operating hours.

Important! When operating in damp places or with high temperature fluctuations. Oil must be changed immediately, should condensate (frothy oil) occur in the gear box.

Important! If the pump is mounted on a vehicle (possibility of unlevelness) and/or if the pump speed is between 300 rpm and 500 rpm, the oil quantity is 1.85 gallon (7.0L). To check, put the oil dipstick in the bore situated beside the eye bolt.

Keep NPSH under control.

Maximum in-pump pressure 145 PSI (10 bar), maximum suction head -4.35 PSI (-0.3 bar).

Safety Rules

Pump operation without safety valve as well as any excess in temperature or speed limits automatically voids the warranty. The safety valve must be regulated in accordance with the guidelines for liquid spraying units so that the admissible operating pressure cannot be exceeded by more than 10%.

When the pump is in operation, the open shaft end must be covered up by shaft protector (21), the driven shaft side and coupling by a contact-protector and the plunger room by cover (30).

Pressure in discharge line and in pump must be at zero before any maintenance to the pump takes place. Close up suction line. Disconnect fuses to ensure that the driving motor does not get switched on accidentally.

Make sure that all parts on the pressure side of the unit are vented and refilled, with pressure at zero, before starting the pump.

In order to prevent air, or an air/water mixture being absorbed and to prevent cavitation occurring, the pump-npshr, positive suction head and water temperature must be kept under control.

Cavitation and/or compressure of gases lead to uncontrollable pressure-kicks which can ruin pump and unit parts and also be dangerous to the operator or anyone standing nearby.

Giant plunger pumps are suitable for pumping clean water and other non-aggressive or abrasive media with a specific weight similar to water.

Before pump other liquids - especially inflammable, explosive and toxic media - the pump manufacturer must under all circumstances be consulted with regard to the resistance of the pump material. It is the responsibility of the equipment manufacture and/or operator to ensure that all pertinent safety regulations are adhered to.

GP7128 Torque Specifications

Position	Lubrication Information	Torque Amount
1	Molycote Cu-Paste	
10		33 ft.-lbs. (45 Nm)
12		59 ft.-lbs. (80 Nm)
24		30 ft.-lbs. (40 Nm)
30A		89 in.-lbs (10 Nm)
32	Loctite 403	
36	Loctite 243	30 ft.-lbs. (40 Nm)
49	Loctite 270	
49A		103 ft.-lbs. (140 Nm)
58C	Pro Pack 550	155 ft.-lbs. (210 Nm)

Specifications Model GP7128

Flow	17.9 GPM.....	67.7 L/M
Discharge Pressure	5800 PSI ¹	400 Bar ¹
Power Consumption	71.4 HP	53.2 kW
Crankshaft Speed	750 RPM
Inlet Pressure (maximum).....	-4.35 to 145 PSI	-0.3 to 10 Bar
Plunger Diameter.....	1.1"	28 mm
Plunger Stroke	2.1"	52 mm
Crankshaft Diameter.....	1.9"	48 mm
Key Width	0.6"	14 mm
Crankshaft Mounting.....	Either side
Shaft Rotation	Top of pulley towards manifold
Temperature of Pumped Fluids.....	140 °F.....	60 °C
Inlet Ports.....	(2) 1-1/4" NPT
Discharge Ports	(2) 3/4" NPT
Weight.....	375 lbs.	170 Kg
Crankcase Oil Capacity	1.6 Gal.	6.0 Liters
Fluid End Material.....	Stainless Steel
Volumetric Efficiency @ 700 RPM	89%
Mechanical Efficiency @ 700 RPM.....	83%

Consult the factory for special requirements that must be met if the pump is to operate beyond one or more of the limits specified above.

NOTES: ¹This specification for maximum pressure and maximum speed apply to intermittent duty. When the pump is used for continuous duty and/or with water warmer than 104 °F (40 °C), these values must be reduced by 10%.

GP7128 Horsepower Requirements Electric Motor					
RPM	GPM	3000 PSI	4000 PSI	5000 PSI	5800 PSI
300	7.2	14.9	19.9	24.8	28.8
400	9.6	19.9	26.5	33.1	38.4
550	13.1	27.1	36.1	45.2	52.4
600	14.3	29.6	39.5	49.3	57.2
650	15.5	32.1	42.8	53.5	62.0
700	16.7	34.6	46.1	57.6	66.8
750	17.9	37.0	49.4	61.7	71.6

HORSEPOWER RATINGS:

The ratings shown in the chart above reflect the horsepower requirements for electric motors. We recommend motors with a 1.15 service factor.

To compute specific pump horsepower requirements, use the following formula:

$$\frac{\text{GPM} \times \text{PSI}}{1450} = \text{hp}$$

Exploded View - GP7128 Pump

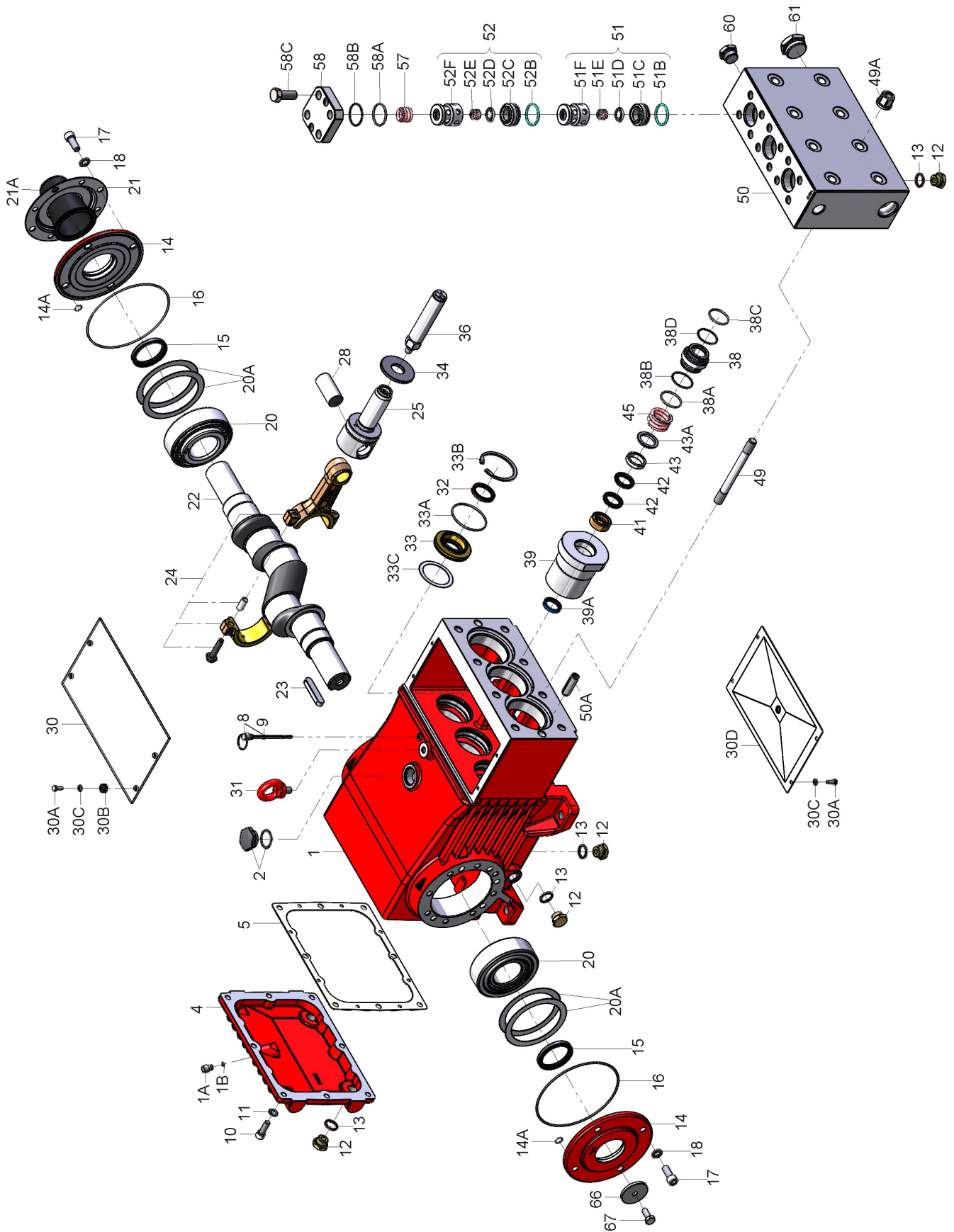

GP7128-0021 PARTS LIST

ITEM	PART	DESCRIPTION	QTY.	ITEM	PART	DESCRIPTION	QTY.
1	05769	Crankcase	1	38C	06736	O-Ring, Viton	3
1A	05525	Head for Oil Dipstick	1	38D	12056	Support Ring for 38C	3
1B	01009	O-Ring, Dipstick	1	39	06426	Seal Sleeve	3
2	13000	Oil Filler Plug Assembly	1	39A	13228	Grooved Ring	3
4	07601	Crankcase Cover	1	41	13417	Pressure Ring	3
5	05798	Seal for Cover	1	42	13369-0020	V-Sleeve, Teflon	6
8	07603	Oil Dip Stick Assembly	1	43	06862	Sleeve Support Ring	3
9	01009	O-Ring, Dip Stick	1	43A	05355	Spacer Ring	3
10	22706	Inner Hexagon Screw	8	45	07173	Tension Spring	3
11	06725	Spring Washer	8	49	13159	Stud Bolt	8
12	07109	Drain Plug	9	49A	13160	Hexagon Nut	8
13	06272	Copper Seal	9	50	06798	Valve Casing	1
14	05770	Bearing Cover	2	50A	13162	Cylinder Stud	2
14A	12204	O-Ring	8	51	04727	Inlet Valve Assembly (51B-F)	3
15	05771	Radial Shaft Seal	2	51B	05193	O-Ring	3
16	05772	O-Ring, Bearing cover	2	51C	04725	Inlet Valve Seat	3
17	05642	Inner Hexagon Screw	8	51D	13130	Valve Plate	3
18	05039	Spring Washer	8	51E	07062-0100	Valve Spring	3
20	05773	Taper Roller Bearing	2	51F	13147	Spacer Pipe	3
20A	05774	Fitting Disc (Shim)	1-8	52	04728	Discharge Valve Assembly (52B-F)	3
21	05645	Holder for Shaft Protector	1	52B	05193	O-Ring	3
21A	05646	Shaft Protector	1	52C	04726	Discharge Valve Seat	3
22	05575	Crankshaft	1	52D	13130	Valve Plate	3
23	07614	Key	1	52E	07062-0100	Valve Spring	3
24	05777	Connecting Rod Assembly	3	52F	13147	Spacer Pipe	3
25	05778	Crosshead Assembly	3	57	06078	Compression Spring	3
28	05779	Crosshead Pin	3	58	07699	Plug	3
30	07619	Cover Plate	1	58A	07700-0001	O-Ring	3
30A	07225-0100	Hexagon Screw	8	58B	07693	Support Ring	3
30B	13136	Grommet	4	58C	07702	Hexagon Screw	12
30C	08280	Disc	8	60	04576	Plug, 3/4" NPT	1
30D	13154	Cover	1	61	12251	Plug, 1-1/4" NPT	1
31	07623	Eye Bolt	1	66	13362	Disc for Crankshaft	1
32	07624	Radial Shaft Seal	3	67	13358	Hexagon Screw	1
33	07626	Seal Retainer	3		07662	Tool for valve assembly	
33A	07627	O-Ring for 33	3		17212	Crankcase Assembly (1-34/49/49A/50A/66/67)	
33B	07628	Circlip for 33	3		04671	Manifold Assembly (50-61 w/out 50A)	
33C	07249	Shim	3		03046	Plunger Replacement Kit (36-45)	
34	13137	Flinger	3				
36	06427	Plunger	3				
38	05354	Seal Case	3				
38A	06577	O-Ring, Viton	3				
38B	07693	Support Ring for 38A	3				

GP7128 Pump Repair Kits

Plunger Packing Kit - 09464-0021

Item	Part #	Description	Qty.
38A	06577	O-Ring	3
38B	07693	Support Ring	3
38C	06776	O-Ring	3
38D	12056	Support Ring	3
39A	13228	Grooved Ring	3
42	13369-0020	V-Sleeve	6
43	06862	Sleeve Support Ring	3

Oil Seal Kit # 09221

Item	Part #	Description	Qty.
32	07624	Radial Shaft Seal	3
33A	07627	O-Ring	3

Valve Assembly Kit - #09520

Item	Part #	Description	Qty.
51B	05193	O-Ring	3
51C	04725	Inlet Valve Seat	3
51D	13130	Valve Plate	3
51E	07062-0100	Valve Spring	3
52B	05193	O-Ring	3
52C	04726	Discharge Valve Seat	3
52D	13130	Valve Plate	3
52E	07062-0100	Valve Spring	3
58A	07700	O-Ring	3
58B	07693	Support Ring	3

GP7128 Repair Instructions

NOTE: Always take time to lubricate all metal and non-metal parts with a light film of oil before reassembling. This step will help ensure proper fit, at the same time protecting the pump non-metal parts (elastomers) from cutting and scoring.

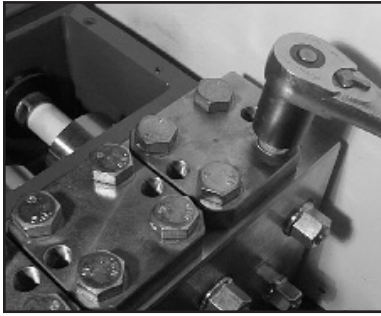

1. Loosen screws (58C), press plugs (58) out of valve casing with two screws - using them like "jack screws".

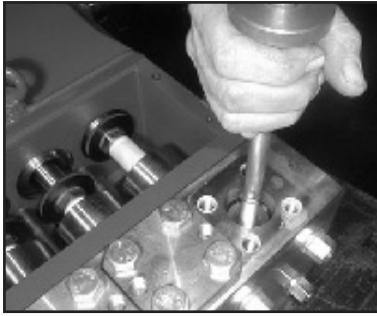

2. Remove tension spring (57) and complete valve assemblies (51 and 52) using either tool (part #07662) or stud bolt.



3. Valve seats (51C and 52C) are pressed out of spacer pipe (51F) by hitting the valve plate (51D) with a bolt.

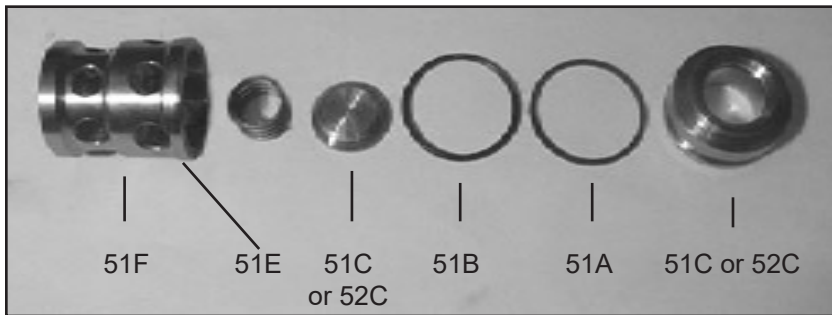

4. Check surfaces of valve plate, valve seat, O-rings (51B, 58A) and replace worn parts.



5. When reassembling: The suction valve seat (51C) is 1mm smaller in diameter than the discharge valve seat (52C). Suction valve seats are marked "S" and always have to be installed first. Discharge valve seats are marked "P" and are always to be installed on top of suction valve. Plugs (58) are to be tensioned down evenly with screws (58C) and cross-wise at 156 ft-lbs. (210 NM).

To Check Seals and Plungers



6. Loosen nuts (49A)



7. Remove pump head.



8. Separate plunger (36) from crosshead (25) by means of an open-end wrench (27mm).



9. Pull seal sleeves (39) out of their fittings in the crankcase. Take seal case (38) out of seal sleeve (39).

GP7128 Repair Instructions

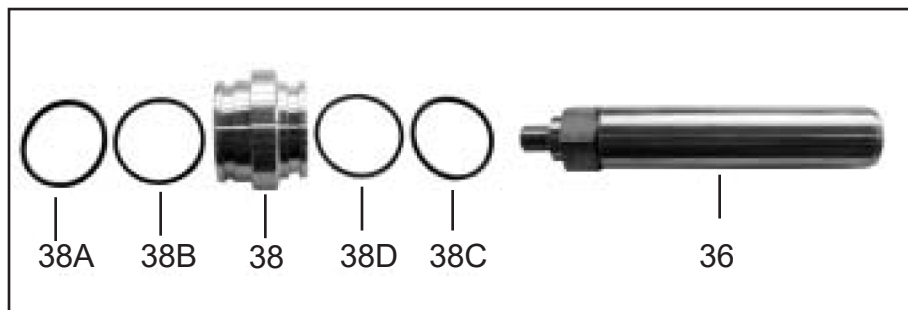

10. If o-rings (38A and 38C) or support rings (38B and 38D) are damaged, replace with new parts. Examine plunger (36) for wear.

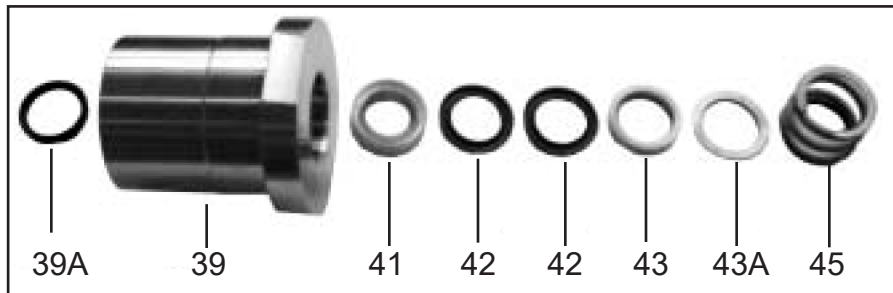

11. Remove tension spring (45). Take a thin screw driver and pry out the grooved ring (39A). **Note: This seal (39A) will not be reusable, so replace with a new part.** For the seal-pack (41-43A), remove with either a socket wrench or use a screw driver to push against the rear lip of the pressure ring (41) or v-sleeves (42). You will need to remove seals evenly out of the seal sleeve (39). **Be careful not to score the sleeve or metal parts (41 & 43).**

CAUTION: Don't loosen the (3) plungers (36) before the valve casing has been removed otherwise the plunger (36) could hit against the spacer pipe (51F) when the pump is being turned. Seal life can be increased if the pretensioning allows for a little leakage. This assists lubrication and keeps the seals cool. It is therefore not necessary to replace seals before the leakage becomes too heavy and causes output and operating pressure to drop.

MOUNTING VALVE CASING

NOTE: Replace worn parts; grease seals with silicone before installing.

12. Check O-rings (38A) and support rings (38B) on seal case (38). Clean surfaces of seal sleeves in gear box and sealing surfaces of valve casing. Reassemble seal sleeve (39) by placing plunger (36) in seal sleeve; place pressure ring (41), v-sleeves (42), sleeve support ring (43), spacer ring (43A) and tension spring (45) over plunger (36). Place the seal case onto the seal sleeve and press into the crankcase, making sure that the weep hole on the seal sleeve is facing down. Tighten plunger onto crosshead (25) with a 27mm open end wrench to 33 ft-lbs. (45NM)
13. Push valve casing carefully onto O-rings of seal case and centering studs (50A). Tighten nuts (49A) to 103 ft-lbs. (140NM).

TO DISASSEMBLE GEAR

14. Take out plunger (36) and seal sleeves (39) as described above. Drain oil.
15. After removing the circlip ring (33B), lever out seal retainer (33) with a screwdriver. Check seals (32,33A) and surfaces of crosshead.
16. Remove crankcase cover (4). Loosen inner hexagon screws on the connecting rods (24) and push conn rod halves as far into the crosshead guide as possible.
- CAUTION:** Connecting rods are marked for identification. Do not twist conn rod halves. Conn rod is to be reinstalled in the same position on crankshaft journals.
17. Check surfaces of connecting rod and crankshaft (22). Take out bearing cover (14) to one side and push out crankshaft taking particular care that the connecting rod (24) doesn't bend.
- CAUTION:** Seal (32) must always be installed so that the seal-lip on the inside diameter faces the oil. Reassemble in reverse order: Regulate axial bearing clearance - minimum 0.1mm, maximum 0.15mm-by means of fitting disc (20A). The crankshaft (22) should turn easily with little clearance. Tighten connecting rod bolts to 30 ft.-lbs.(40 NM)
- CAUTION:** Connecting rod (24) has to be able to be slightly moved sidewise at the stroke journals.

GP7128 Dimensions - Inches (mm)

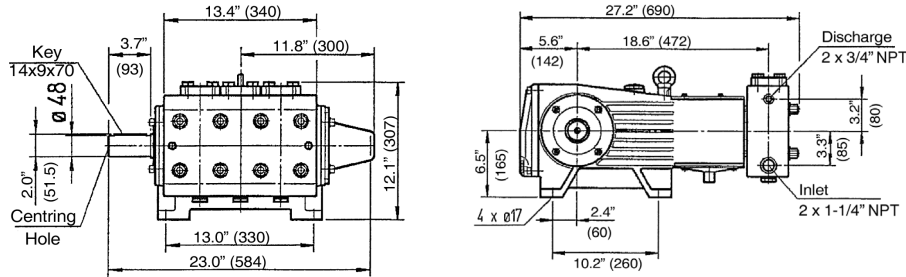

GIANT INDUSTRIES LIMITED WARRANTY

Giant Industries, Inc. pumps and accessories are warranted by the manufacturer to be free from defects in workmanship and material as follows:

1. Five (5) years from the date of shipment for all pumps used in portable pressure washers with NON-SALINE, clean water applications.
2. Two (2) years from the date of shipment for Giant pumps used in car wash applications.
3. One (1) year from the date of shipment for all other Giant industrial and consumer pumps.
4. Six (6) months from the date of shipment for all rebuilt pumps
5. Ninety (90) days from the date of shipment for all Giant accessories.

This warranty is limited to repair or replacement of pumps and accessories of which the manufacturer's evaluation shows were defective at the time of shipment by the manufacturer. The following items are NOT covered or will void the warranty:

1. Defects caused by negligence or fault of the buyer or third party.
2. Normal wear and tear to standard wear parts.
3. Use of repair parts other than those manufactured or authorized by Giant.
4. Improper use of the product as a component part.
5. Changes or modifications made by the customer or third party.
6. The operation of pumps and or accessories exceeding the specifications set forth in the Operations Manuals provided by Giant Industries, Inc.

Liability under this warranty is on all non-wear parts and limited to the replacement or repair of those products returned freight prepaid to Giant Industries which are deemed to be defective due to workmanship or failure of material. A Returned Goods Authorization (R.G.A.) number and completed warranty evaluation form is required prior to the return to Giant Industries of all products under warranty consideration. Call (419)-531-4600 or fax (419)-531-6836 to obtain an R.G.A. number.

Repair or replacement of defective products as provided is the sole and exclusive remedy provided hereunder and the MANUFACTURER SHALL NOT BE LIABLE FOR FURTHER LOSS, DAMAGES, OR EXPENSES, INCLUDING INCIDENTAL AND CONSEQUENTIAL DAMAGES DIRECTLY OR INDIRECTLY ARISING FROM THE SALE OR USE OF THIS PRODUCT.

THE LIMITED WARRANTY SET FORTH HEREIN IS IN LIEU OF ALL OTHER WARRANTIES OR REPRESENTATION, EXPRESS OR IMPLIED, INCLUDING WITHOUT LIMITATION ANY WARRANTIES OR MERCHANTABILITY OR FITNESS FOR A PARTICULAR PURPOSE AND ALL SUCH WARRANTIES ARE HEREBY DISCLAIMED AND EXCLUDED BY THE MANUFACTURER.



WARNING: This product might contain a chemical known to the State of California to cause cancer, and birth defects or other reproductive harm.

For more information go to www.P65Warnings.ca.gov