

Model GP8076

Triplex Ceramic
Plunger Pump
Models Manual

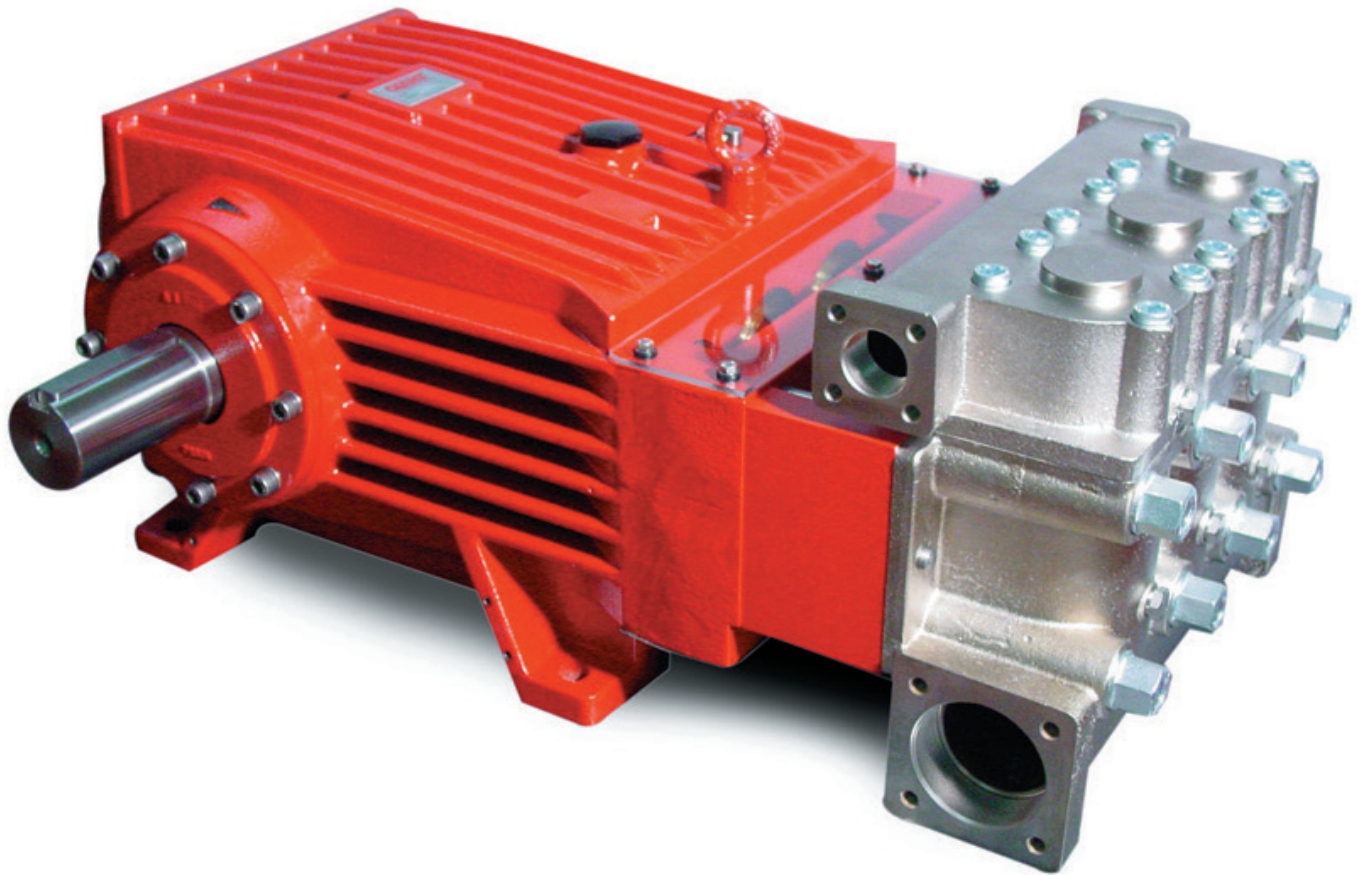

GIANT
Performance Under Pressure

Contents:

Pump Specifications:	page 2
Installation Instructions:	page 3
Exploded View/Parts List:	page 4
Parts List:	page 5
Repair Kits/Tool List:/Torque Specifications	page 6
Repair Instructions:	page 7
Dimensions:	back page
Warranty Information	back page

Specifications - GP8076

1. Performance

	U.S.	(Metric)
Flow	132 GPM	(500 LPM)
Discharge Pressure	1500 PSI	(100 bar)
Power Consumption	129 BHP.....	96 kW
Maximum Speed.....		520 RPM
Inlet Pressure	29 PSI	(2.0 bar)
Plunger Diameter.....	2.99".....	76 mm
Plunger Stroke.....	2.83".....	72 mm
Crankshaft Diameter.....	2.76".....	70 mm
Key Width		B20 x 12 x 10
Crankshaft Mounting		Either side
Shaft Rotation.....		Top of pulley towards manifold
Temperature of Pumped Fluids	86° F	(30° C)*
Inlet Ports		(2) 3" BSP
Discharge Ports.....		(2) 1-1/4" BSP
Weight	749 lbs.	(340 kg)
Crankcase Oil Capacity.....	3.3 Gal.	(12.5 liters)
Valve Casing Material.....		Nickle plated Spheroidal Cast Iron
NPSHR.....	23.0 ft.-head.....	7.0 mWs

*higher water temperatures possible with separate crankcase cooling system; contact Giant.

GP8076 HORSEPOWER REQUIREMENTS					
RPM	GPM	500 PSI	1000 PSI	1250 PSI	1500 PSI
260	66.0	22.8	45.5	56.9	68.3
300	76.2	26.3	52.6	65.7	78.8
400	102	35.2	70.4	87.9	105.5
520	132	45.5	91.0	113.8	136.6

1) Figures given for maximum pressure and maximum speed (rpm) apply to intermittent operation with cold water.

Definition of intermittent operation:

Operation at full performance for not more than altogether 20 minutes an hour, with the pump running without pressure or turned off inbetween. For example, this can be full load operation for 5 minutes four times an hour with 10 minute breaks inbetween or continuous full load operation for 20 minutes followed by a 40 minute break.

2) Higher water temperatures are possible with a separate external crankcase cooling system. The manufacturer is to be contacted in this case.

3) The maximum pressure is to be reduced by 10% where continuous operation with a cooler (with or without gear) is involved.

NPSHR / Inlet pressure

Required NPSH refers to water at 68 °F (20 °C) at maximum permissible pump speed.

The inlet pressure on the suction side must not exceed 29 PSI (2 bar).

Level of noise emission

Emission sound pressure level: ≤ 94 dB(A)

2. Fields of application

The fields of application of these pump types correspond to the specifications in the assembly instructions GIANT INDUSTRIES.

Ambient conditions

Ambient temperature:

41 °F (5 °C) < T_{Amb.} < 86 °F (30 °C)

4. Oil filling

- Filling quantity: **3.3 gal (12.5 L)**
- Quality: Industrial gear oil **ISO VG 220** or automotive gear oil **SAE 90 GL4 - Giant's p/n 01154**
- Intervals: first oil change after **50 operating hours** then every **1000 operating hours**, but at the latest **12 months**



If the pump is mounted on a vehicle (possible inclined position during operation) and/or if the pump speed is between 300 rpm and 500 rpm, the required oil quantity increases by 0.26 gallons (1 liter).

5. Installation/ Putting into Operation

5.1 Shaft protector

When the pump is in operation, the driven shaft side and coupling by a shaft guard and the plunger room by cover (30).

Do not step onto the protective plate (30) nor put heavy objects on it.

5.2 Direction of pump rotation

An arrow on the pump crankcase indicates the recommended direction of rotation for the drive shaft. The indicated direction ensures that oil is correctly distributed on and into the crosshead guides via optimal connecting rod motion thus providing best possible lubrication particularly with regard to continuous operation.

The pump can also be run against the recommended direction of rotation if operated periodically or at reduced pressure.

If so, the pump must be run in in this direction to smoothen the bearing areas.

This is done by initially operating the pump at zero pressure for 30 minutes; thereafter the pressure is to be slowly increased over a period of an hour to the desired maximum operating pressure.

Check the oil temperature during this process.

5.3 Suction line filter

Recommended mesh size 200 µm.

5.4 Gear oil cooling



The pumps can be run without gear oil cooling in continuous operation **up to** a power rating of **107.2 HP (80 kW)** or with major intermittent operation at full performance.

If operational power **exceeds 107.2 HP (80 kW)** in continuous operation, the pump must be run with the integrated oil cooling system. The max. temperature of the water being pumped and which is also fed through the cooling system must not exceed 86 °F (30 °C).

The water amount which is fed into the cooling system depends on the pump speed and is approx. 1.8 GPM (7.0 l/min.) at nominal speed. The cooling water is sucked in by one of the pumping chambers and pumped away.



If higher medium temperatures or liquids other than water are involved or aggressive media such as seawater, demineralised water etc., the pump must be fitted with a separate cooling circuit. The separate cooler must have a cooling efficiency of 1700 watt.

If there is a danger of frost, an appropriate amount of antifreeze must be mixed into the cooling circuit.

5.5 Valve Casing



The torque tension on the valve casing nuts (49A) is to be checked after approximately 200 operating hours. Please see the section 'Maintenance and Servicing' concerning the torque values.

The pump must be at zero pressure when checking the torque tension.

6. Operation

When starting up for work, the pump must run first at zero pressure for approximately 1 minute.



The pump and cooling system must be emptied if there is a danger of frost. Note that travel wind, for example, can cause water in pumps fitted on open vehicles to freeze even if the outside temperature is above freezing point.

Empty the pump through the second unused suction and discharge connection using compressed air, for example.

Bottom plugs (12) on the suction channel can be opened as well.

The pump can also be run "dry" for 1-2 minutes to aid emptying.

Empty the cooling system by removing screw joints (K11) on the pump head (50) and by blowing the hoses (K12) with compressed air on the (K11/K7) side.



The service life of the seals is maximized if a minimal amount of leakage is present. A few drops of water can drip from each plunger every minute.

Leakage has to be examined every day; the plunger seals must be changed should leakage become excessive (=constant dripping).

Exploded View - GP8076

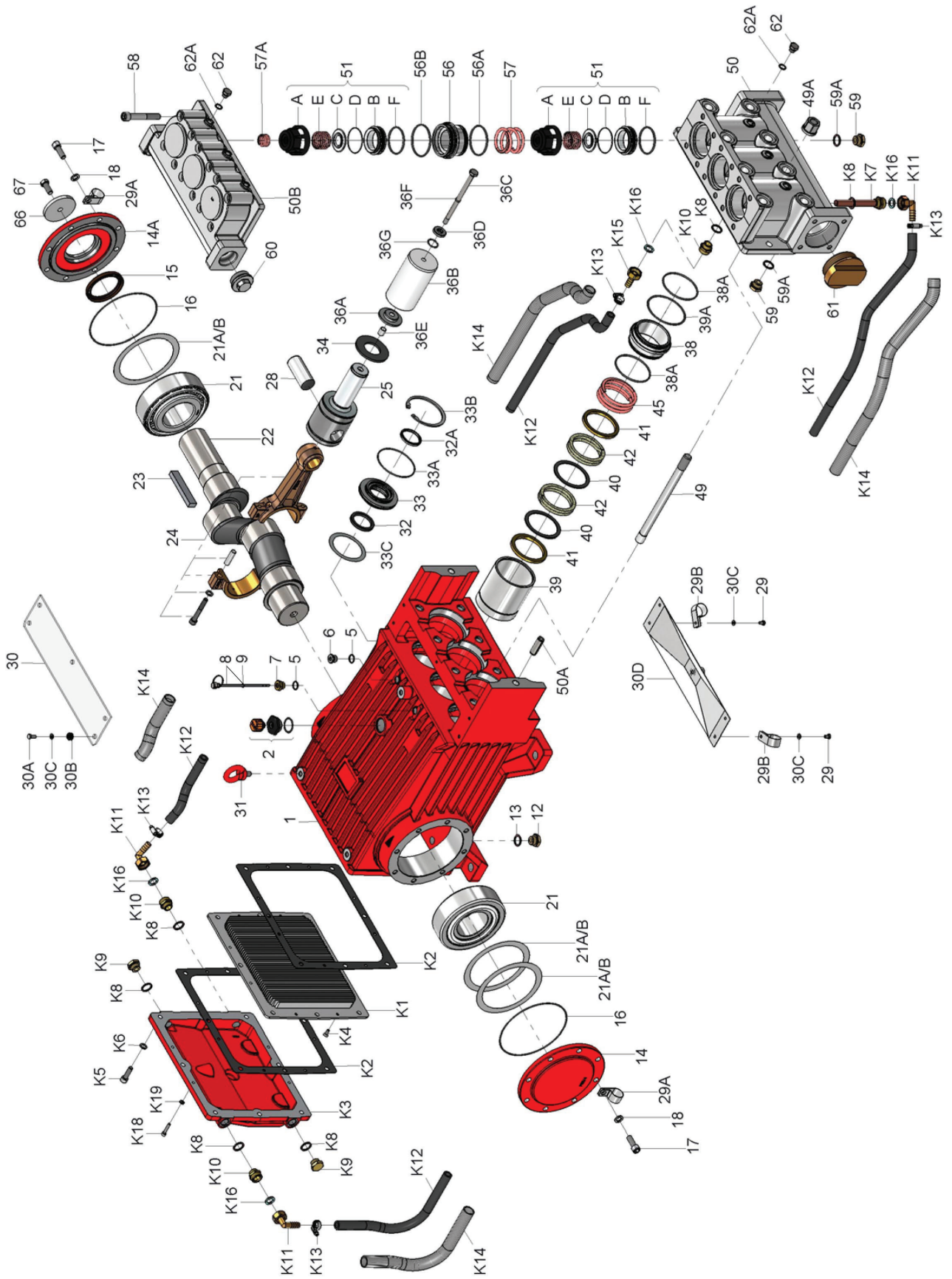

Part List - GP8076

<u>Item</u>	<u>Part</u>	<u>Description</u>	<u>Qty</u>	<u>Item</u>	<u>Part</u>	<u>Description</u>	<u>Qty</u>
1	05380	Crankcase	1	41	03567	Guide Ring	6
2	06893	Oil Filler Plug Assy with Vent	1	42	03568	Spiral Ring	6
5	22929	Copper Washer	2	45	03569	Pressure Spring	3
6	12256	Plug, 3/8" BSP	1	49	05072	Stud Bolt	8
7	05656	Plug for Oil Dipstick	1	49A	05073	Hexagon Nut	8
8	05035	Oil Dipstick Assembly	1	50	03570	Valve Casing	1
9	01009	O-Ring	1	50A	13162	Centering Stud	2
12	07109	Plug 1/2" BSP	2	50B	03571	Discharge Valve Casing	1
13	06272	Seal	2	51	03572	Valve Assembly	6
14	05036	Bearing Cover Closed	1	51A	03573	Spring Tension Cap	6
14A	05298	Bearing Cover Open	1	51B	03574	Valve Seat	6
15	05112	Radial Shaft Seal	1	51C	03575	Valve Plate	6
16	05037	O-Ring	2	51D	06560	O-Ring	6
17	05038	Hexagon Socket Screw	16	51E	05080	Valve Spring	6
18	05039	Spring Ring	16	51F	03434	O-Ring	6
21	05044	Tapered Roller Bearing	2	56	03576	Discharge Valve Adaptor	3
21A	05042	Fitting Disc	1-5	56A	04955	O-Ring	3
21B	05043	Fitting Disc	1-5	56B	13156	O-Ring	3
22	05299	Crankshaft	1	57	05086	Pressure Spring	3
23	05104	Fitting Key	1	57A	07210-0100	Pressure Spring	3
24	05047	Connecting Rod Assembly	3	58	05087	Hexagon Socket Screw	12
25	05048	Crosshead c/w Plunger	3	59	07109	Plug 1/2" BSP	2
28	05049	Crosshead Pin	3	59A	06272	Copper Seal	2
29	05051	Hexagon Screw	4	60	13322	Plug 1-1/2" BSP	1
29A	05381	Bracket 1 for Cooling Hose	2	61	05088	Plug 3" BSP	1
29B	05383	Bracket 2 for Cooling Hose	2	62	05302	Plug 1/4" BSP	6
30	05052	Cover Plate	1	62A	06934	Copper Gasket	6
30A	07225-0100	Hexagon Screw	5	66	05303	Disc for Crankshaft	1
30B	13136	Grommet	5	67	13433	Hexagon Screw	1
30C	05053	Washer	9	68	07662	Valve Puller Tool (Not shown)	1
30D	05050	Splash Cover	1	78	05025	Oil Cooler Assembly	1
31	07623	Eye Bolt	3	K1	05026	Cooling Vane Plate	1
32	05058	Radial Shaft Seal	3	K2	05027	Seal for Gear Cover	2
32A	03118	Scraper	3	K3	05028	Gear Cover	1
33	03119	Seal Retainer	3	K4	05029	Hexagon Head Countersunk Screw	4
33A	05056	O-Ring	3				
33B	05054	Clip Ring	3	K5	07381	Hexagon Socket Screw	8
33C	05059	Fitting Disc	3	K6	08041	Washer	8
34	03560	Oil Shield	3	K7	05030	Connection for Oil Cooler	1
36A	05063	Cover for Plunger Pipe	3	K8	06272	Copper Seal	6
36B	03561	Plunger Pipe	3	K9	07109	Plug 1/2" BSP	2
36C	03562	Tension Screw	3	K10	05031	Connecting Branch	3
36D	03577	Washer	3	K11	05032	Hose Adaptor	3
36E	06900	Centering Sleeve	3	K12	05033	Tube for Cooler	2
36F	22704	O-Ring	3	K13	05402	Hose Clamp	4
36G	12092	O-Ring	3	K14	05403	Hose Guard	2
38	03563	Seal Case	3	K15	05404	Hose Coupling Nut	1
38A	03564	O-Ring	6	K16	05405	Flat Gasket	4
39	03565	Seal Sleeve	3	K18	04158	Hexagon Socket Screw	4
39A	05066	O-Ring	3	K19	05053	Washer	4
40	03566	Support Ring	6				

GP8076 PUMP REPAIR KITS

Plunger Packing Kit - #09861

Item	Part #	Description	Qty.
38A	03564	O-Ring	6
39A	05066	O-Ring	3
40	03566	Support Ring	6
41	03567	Guide Ring	6
42	03568	Spiral Ring	6

Valve Repair Kit - #09862

Item	Part #	Description	Qty.
51B	03574	Valve Seat	6
51C	03575	Valve Plate	6
51D	06560	O-Ring	6
51E	05080	Valve Spring	6
51F	03434	O-Ring	6
56A	06258	O-Ring	3
56B	13156	O-Ring	3

Oil Seal Kit - #09584A

Item	Part #	Description	Qty.
32	05058	Radial Shaft Seal	3
32A	03118	Scraper	3
33A	05056	O-Ring	3

GP8076 TORQUE SPECIFICATIONS

Position	Item #	Thread	Description	Lubrication Info	Torque Amount
12	07109	1/2" BSP	Plug, 1/2" BSP		59 ft.-lbs. (80 Nm)
15	05112		Radial Shaft Seal	Loctite 403	
17	05038	M12	Hexagon Socket Screw		64 ft.-lbs. (87 Nm)
24	05047	M10	Connecting Rod Assembly		36.9 ft.-lbs. (50 Nm)
32	05058		Radial Shaft Seal	Loctite 403	
36C	03562	M10	Tension Screw	Loctite 243	30 ft.-lbs. (40 Nm)
39	03565		Seal Sleeve	Anti-Seize 350 Crankcase Side	
49	05072	M20	Stud Bolt	Loctite 648 Crankcase Side	
49A	05073	M20	Hexagon Nut		266 ft.-lbs. (360 Nm)
58	05087	M14	Hexagon Socket Screw	Anti-Seize 350	103 ft.-lbs. (140 Nm)
59	07109	1/2" BSP	Plug, 1/2" BSP		59 ft.-lbs. (80 Nm)
K4	05029	M6	Hexagon Head Countersunk Screw		133 in.-lbs. (15 Nm)
K5	07381	M10	Hexagon Socket Screw		33 ft.-lbs. (45 Nm)
K9	07109	1/2" BSP	Plug, 1/2" BSP		59 ft.-lbs. (80 Nm)
K18	04158	M6	Hexagon Socket Screw		133 in.-lbs. (15 Nm)

GP8000 Troubleshooting

Problem	Cause	Solution
Pressure drops, water leaks	V-sleeves leak	Replace V-sleeves, examine surface of plunger
Pressure drops, pump becomes loud	Discharge or suction valve leaks	Replace valve
	Steam formation (cavitation)	Reduce suction height, reduce flow resistance in inlet line, clean inlet filter, lower water temperature
Irregular pressure	Worn valves	Examine valves
	O-Ring on the valves or inlet valve adapter leaks	Examine O-ring, examine valve casing for unevenness on the sealing surfaces
Oil leaks at visible part of plunger	Gear sealing is leaky	Examine seals and running surface of plunger
Dirty mile-colored frothy oil	Oil has mixed with water	Replace oil immediately, find and fix the cause
Oil leakage on the crankshaft	Shaft seal ring leaks	Check seal and shaft
Noise increases without loss of pressure	Worn bearing	Dismantle gear, examine all parts, replace worn parts, check oil level. If service life was too short, check for excess strain or whether lubrication intervals were too long. Only specified lubricants are to be used

GP8076 PUMP REPAIR INSTRUCTIONS

7. Maintenance and Servicing

Based on the thread type and the required tightening torques, observe the table on page 6.

7.1 Special tools required

The following special tools are required for assembly:
- Assembling tool (code no. 15.0038)

7.2 Suction and Discharge Valves

Loosen screws (58), lift discharge valve casing (50B) up and away.

Take out pressure springs (57).

Pull out the complete valves (51) together with the pressure valve holder (56) using an assembly tool (order no. 07662).

To dismantle valves:

The spring tension cap (51A) is screwed together with the valve seat (51B).

Screw off spring tension cap, take out springs (51E) and valve plate (51C).

Check sealing surfaces and O-rings (51D, 51F).

Replace worn parts.

Before re-fitting the valves, clean the sealing surfaces in the casing and check for any damage.

Tighten screws (58) to the required torque.

Check torque tension after 8-10 operating hours.

8.3 Seals and Plunger

Screw off hexagon nuts (49A) and hose coupling (K11 and K15), remove pump head together with seal case (38) from crankcase (1).

If necessary, carefully tap the valve casing (50) past the centring stud (50A) using a rubber hammer.



If necessary, support the pump head by resting it on wooden blocks or by using a pulley.

Remove tension screw (36C) and take seal sleeve (39) together with all mounted parts out of the drive.

Pull plunger pipe out of seal assembly and check for any damage.

Pull out spiral rings (42), guide rings (41) and support rings (40) and check for any damage.



Be careful not to damage seal sleeve (39) and guide ring (41).

Check the inner diameter of the guide ring for wear and if necessary replace together with spiral ring (42) and support ring (40).
Clean all parts.

New parts should be lightly coated with silicon grease before installation.

Insert the seal unit (40, 41, 42, 43) into the sleeve.

Push the ceramic plunger carefully through the seals from the crankcase side. If necessary, the seals can be held tightly using a suitable pipe support held on the other side of the seal sleeve.

Take out the seal case (38) from the valve casing (50) and check O-rings (38A) (if necessary secure 2 screwdrivers in the front O-ring groove to extract seal casing from valve casing).

Coat seals with silicon grease before installing.



Mounting surfaces of the crankcase and valve casing must be clean and free of damage.

The components must lie exactly and evenly on one another.

The same exactness applies for all centring positions in the crankcase, intermediate casing, pressure- and valve casing.

They must stand vertically on each other.

Coat the seal sleeve lightly with anti-corrosive grease (e.g. molycote no. Cu-7439) in its fitted area towards the crankcase.

Insert seal sleeves into their crankcase fittings.

Coat the threads of the tension screw (36C) lightly with thread glue and insert it together with a new copper ring (36D) through the ceramic pipe.

Turn the pump by hand until the plunger (25) rests against the plunger pipe.

Tighten tension screw to the required torque.



Thread glue must never come between the plunger pipe (36B) and centring sleeve (36E).

Overtensioning of the plunger pipe by excessive tightening of the tension screw and/or dirt or damage on the mounting surfaces can lead to plunger pipe breakage.

Insert the seal tension spring (45) and O-rings (38A, 39A) in to the seal sleeve (39).

Mounting Valve Casing:

Put seal cases (38) in the centring holes of the valve casing, then push valve casing carefully onto centring studs (50A).

Tighten hexagon nuts evenly and crosswise to the required torque.



The torque tension on the screws (49A) must be checked after 8-10 operating hours; the pump must be at zero pressure.

Thereafter the tension is to be checked every 200 operating hours.

If required, supplementary assembly instructions can be requested from the manufacturer Giant Industries.

GP8076 PUMP DIMENSIONS - (mm)

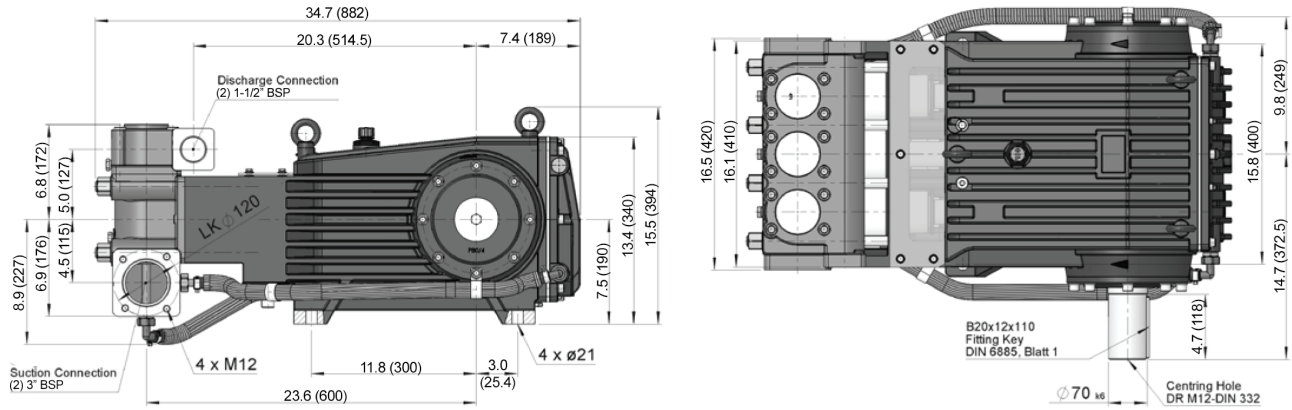

GIANT INDUSTRIES LIMITED WARRANTY

Giant Industries, Inc. pumps and accessories are warranted by the manufacturer to be free from defects in workmanship and material as follows:

1. Five (5) years from the date of shipment for all pumps used in portable pressure washers with NON-SALINE, clean water applications.
2. Two (2) years from the date of shipment for Giant pumps used in car wash applications.
3. One (1) year from the date of shipment for all other Giant industrial and consumer pumps.
4. Six (6) months from the date of shipment for all rebuilt pumps
5. Ninety (90) days from the date of shipment for all Giant accessories.

This warranty is limited to repair or replacement of pumps and accessories of which the manufacturer's evaluation shows were defective at the time of shipment by the manufacturer. The following items are NOT covered or will void the warranty:

1. Defects caused by negligence or fault of the buyer or third party.
2. Normal wear and tear to standard wear parts.
3. Use of repair parts other than those manufactured or authorized by Giant.
4. Improper use of the product as a component part.
5. Changes or modifications made by the customer or third party.
6. The operation of pumps and or accessories exceeding the specifications set forth in the Operations Manuals provided by Giant Industries, Inc.

Liability under this warranty is on all non-wear parts and limited to the replacement or repair of those products returned freight prepaid to Giant Industries which are deemed to be defective due to workmanship or failure of material. A Returned Goods Authorization (R.G.A.) number and completed warranty evaluation form is required prior to the return to Giant Industries of all products under warranty consideration. Call (419)-531-4600 or fax (419)-531-6836 to obtain an R.G.A. number.

Repair or replacement of defective products as provided is the sole and exclusive remedy provided hereunder and the MANUFACTURER SHALL NOT BE LIABLE FOR FURTHER LOSS, DAMAGES, OR EXPENSES, INCLUDING INCIDENTAL AND CONSEQUENTIAL DAMAGES DIRECTLY OR INDIRECTLY ARISING FROM THE SALE OR USE OF THIS PRODUCT.

THE LIMITED WARRANTY SET FORTH HEREIN IS IN LIEU OF ALL OTHER WARRANTIES OR REPRESENTATION, EXPRESS OR IMPLIED, INCLUDING WITHOUT LIMITATION ANY WARRANTIES OR MERCHANTABILITY OR FITNESS FOR A PARTICULAR PURPOSE AND ALL SUCH WARRANTIES ARE HEREBY DISCLAIMED AND EXCLUDED BY THE MANUFACTURER.



WARNING: This product might contain a chemical known to the State of California to cause cancer, and birth defects or other reproductive harm.
For more information go to www.P65Warnings.ca.gov

GIANT
Performance Under Pressure

GIANT INDUSTRIES, INC.

900 N. Westwood Ave.
Toledo, Ohio 43607
(419) 531-4600
FAX (419) 531-6836
www.giantpumps.com
© Copyright 2023 Giant Industries, Inc.