

# Model GP7522GBHS-180

Triplex Ceramic  
Plunger Pump  
Operating Instructions/  
Repair and Service Manual

Gearbox Versions for Pinion Shaft Drives with gearbox in 180° position

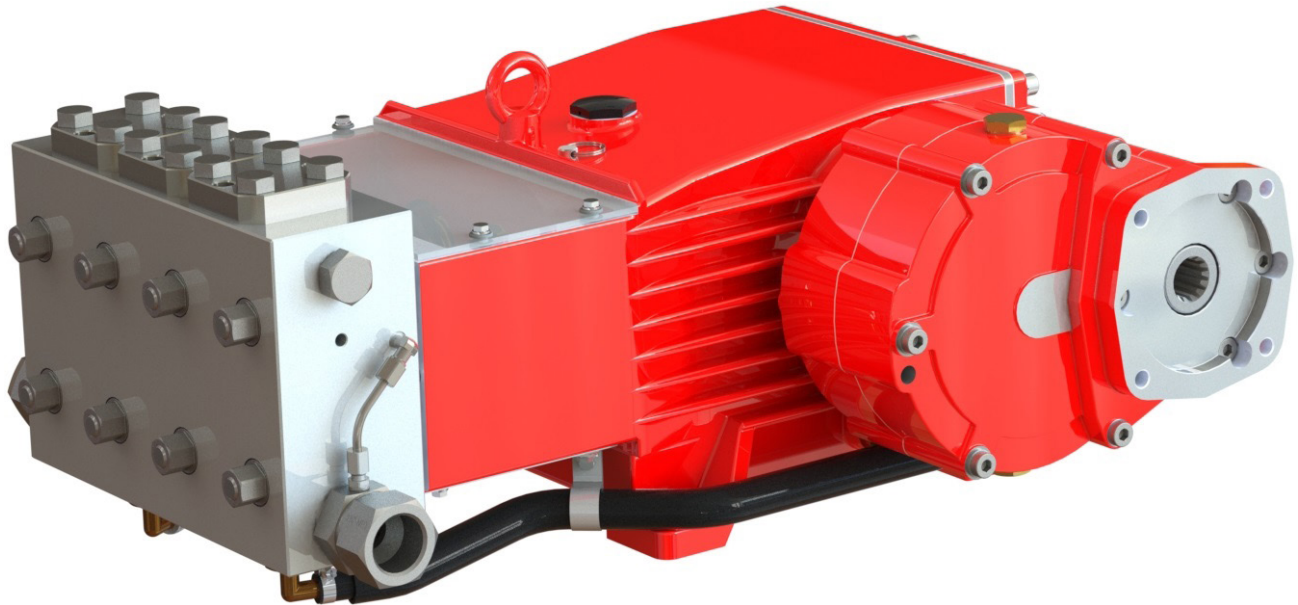

Updated 02/23

## Contents:

Installation Instructions:	page 2
Pump Specifications:	page 3
Exploded View:	page 4
Parts List:	page 5
Kits:	page 6
Torque Specifications:	page 6
Repair Instructions:	pages 7-10
Dimensions:	page 11
Warranty Information:	back page

# INSTALLATION INSTRUCTIONS

## Operation and Maintenance

Check oil level prior to starting and ensure trouble-free water supply.

**Oil:** Use only 1.6 gallons (6.0 liters) of SAE 80W-90 Industrial Gear Lube Oil (Giant's p/n 01154). Initial change after 50 hours and then after every 500 operating hours. If used less than this, change once per year.

**IMPORTANT!** When operating in humid areas (or areas with large temperature fluctuations, the oil must be changed immediately (if condensate or frothy oil occurs in the crankcase).

**IMPORTANT!** We recommend that both inlet ports be used in order to ensure cavitation-free operation and optimal suction conditions. If only one connection is use, a safety margin of 3 feet (1 meter) has to be added to the required NPSH.

**IMPORTANT!** If the pump is mounted on a vehicle with the possibility of unlevelness and/or the pump speed is between 300 & 500 RPM, the volume of oil should be 1.93 gallons (7.3 liters). To check, put the oil dipstick in the bore situated next to the eye bolt.

**IMPORTANT!** The GP7645GB, GP7650GB and GP7655GB pumps have a black arrow on the reduction gear, which shows the preferred direction of rotation. The pump can be delivered either with the gear on the left side or right side (when facing the front of the pump), which eases planning assembled units with regard to the desired direction or rotation. **In either case, the larger gear wheel must rotate towards the front-end of the pump.**

The preferred/optimal direction of rotation ensures that the oil is correctly splashed on the crosshead guides via the motion of the connecting rods, which is a particular advantage where continuous operation is involved.

The pump can also be run against the recommended direction of the rotation if operated periodically or at reduced pressure. If this is the case, the pump has to be run in this direction to smoothen the bearing areas. This is done by a one-time operation at zero pressure for at least 30 minutes; thereafter, the pressure must be slowly increased over the next hour to the desired maximum operating pressure. This should run-in the pump, but you should also check the oil temperature, which should not exceed 160 ° F (71 °C).

The torque tension on the valve casing nuts (49A) is to be checked after approximately 200 hours. Please see page 6 for torque values.

**IMPORTANT!** The service life of the seals is maximized if a minimal amount of leakage is present. A few drops of water can drip from each plunger every minute. Leakage has to be examine every day. If the leakage becomes excessive (constant dripping), the plunger seals must be changed.

## Safety Rules

**The operating instructions must be read and adhered to before performing any work on the pump or complete assembled unit. No responsibility will be carried by us for damage to materials or persons caused by improper handling of our pumps.**

Access to the pump is not allowed by unauthorized personnel. As safety valve is to be installed in accordance with the guidelines for liquid spraying units, so that the admissible operating pressure cannot be exceeded by more than 10%. Pumps operating without a safety valve as well as any excess in temperature or speed limits automatically voids the warranty. When the pump is in operating, the exposed shaft side, the driven shaft side and its coupling must be covered by a protective guard. The plunger area must also be covered by the protective plate (30). Do not step onto the protective plate (30) or put weight on it.

Before carrying out any maintenance work to the pump or pump unit, the pressure in the discharge line and pump must be at zero. Close off the suction line. Disconnect fuses to ensure that the driving motor cannot accidentally get switched on. Before starting the pump, make sure that the pump, the cooling system and all parts on the pressure side of the unit are vented and refilled with pressure at zero.

In order to prevent air or air/water-mixture being absorbed and cavitation occurring, the pump NPSHR (Net Positive Suction Head Required) and water temperature must be adhered to.

**Cavitation and/or compression of gases lead to uncontrollable pressure kicks, which can ruin the pump and unit parts and also be dangerous to the operator or anyone standing nearby.**

Giant plunger pumps are only suitable for pumping fresh clean water.

**NOTE: Contact Giant Industries for Service School Information. Phone: (419)-531-4600.**

# Specifications Model GP7522GBHS-180

	U.S.	Metric
Flow .....	9.9 GPM.....	37.5 L/min
Discharge Pressure .....	10,150 PSI.....	700 Bar
Crankshaft Speed.....		750 RPM
Power Consumption .....	69.3 BHP .....	51.7 kW
Inlet Pressure (with cooling) .....	-4.35 to 29 PSI.....	-0.3 to 2 Bar
Inlet Pressure (without cooling) .....	-4.35 to 145 PSI.....	-0.3 to 10 Bar
Plunger Diameter.....	0.87".....	22mm
Plunger Stroke.....	1.89".....	48mm
Pinion Shaft Diameter.....	1.38".....	35 mm
Key .....		A10 x 8 x 50
Crankshaft Mounting .....		Either side
Pinion Shaft Rotation.....		Towards back of the pump
Temperature of Pumped Fluids .....	140 °F .....	60 °C
Inlet Ports .....		(2) 1-1/4" NPT
Discharge Ports.....		(2) 3/4" NPT
Weight .....	408 lbs. ....	185 kg
Crankcase Oil Capacity.....	1.6 Gal. ....	6 Liters
Fluid End Material.....		Stainless Steel
Volumetric Efficiency @ 750 RPM.....		89%
Mechanical Efficiency @ 750 RPM .....		83%

Consult the factory for special requirements that must be met if the pump is to operate beyond one or more of the limits specified above.

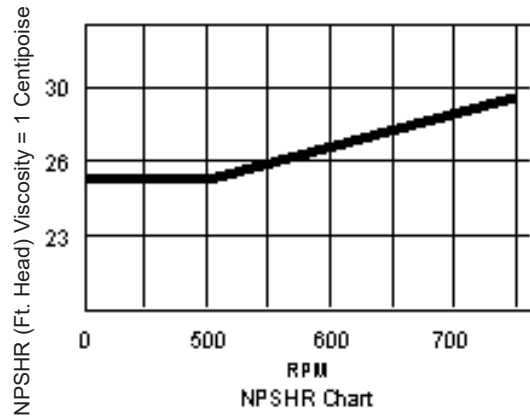
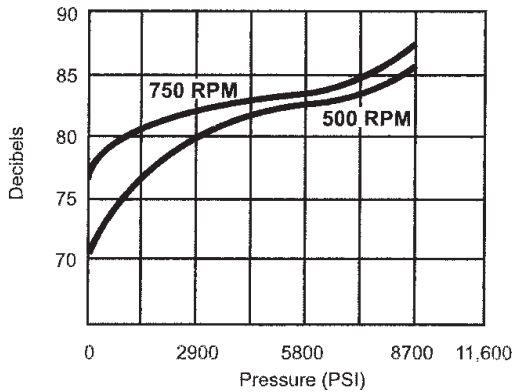

**Materials Used for GP7522 Pump:**

Manifold:..... Stainless Steel  
 Plungers ..... Hard Metal Coating  
 Valves..... High Grade Stainless Steel  
 Seals..... Graphite Impregnated Rope Packing  
 Gear End..... Spheroidal Cast Iron

<b>GP7522GBHS-180 Gear Ratios</b>	
2.25:1	1687 RPM
2.44:1	1830 RPM
2.73:1	2047 RPM

# Exploded View - GP7522GBHS-180

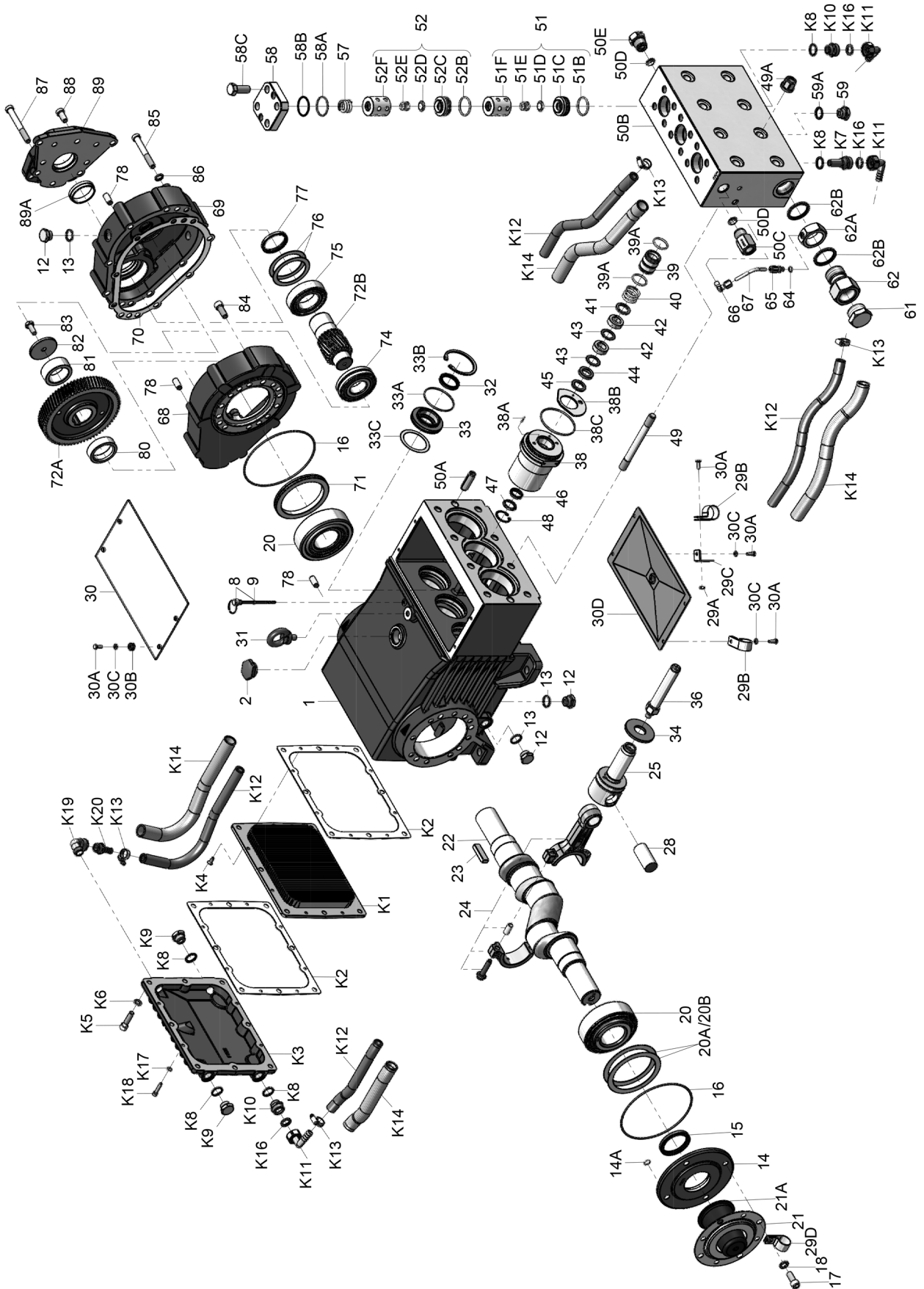



## GP7522GBHS-180 PARTS LIST

<u>ITEM</u>	<u>PART</u>	<u>DESCRIPTION</u>	<u>QTY.</u>	<u>ITEM</u>	<u>PART</u>	<u>DESCRIPTION</u>	<u>QTY.</u>
1	05769	Crankcase	1	51E	06762	Valve Spring	3
2	13000	Oil Filler Plug Assembly	1	51F	06763	Spacer Pipe	3
8	07603	Oil Dip Stick Assembly	1	52	05781	Discharge Valve Assembly	
9	01009	O-Ring, Dip Stick	1			(52B-52F)	3
12	07109	Drain Plug	6	52B	05193	O-Ring	3
13	06272	Copper Seal for 12	6	52C	05195	Discharge Valve Seat	3
14	05770	Bearing Cover	1	52D	06761	Valve Plate	3
14A	12204	O-Ring	4	52E	06762	Valve Spring	3
15	05771	Radial Shaft Seal	1	52F	06763	Spacer Pipe	3
16	05772	O-Ring	2	57	06078	Tension Spring	3
17	05642	Hexagon Socket Screw	4	58	07699	Plug	3
18	05039	Spring Washer	4	58A	07700	O-Ring	3
20	05773	Taper Roller Bearing	2	58B	07693	Support Ring	3
20A	05774	Fitting Disc (Shim), 0.1 mm	1-5	58C	07702	Hexagon Screw	12
20B	04570	Fitting Disc (Shim), 0.15mm	1-5	59	07109	Plug, 1/2" BSP	1
21	05645	Shaft Guard Holder	1	59A	06807	Copper Ring	1
21A	05646	Shaft Guard	1	61	12251	Plug 1-1/4" NPT	1
22	05775	Crankshaft	1	62	03401	Connecting Joint	2
23	05776	Key	1	62A	06766	Connection Ring	2
24	05777	Connecting Rod Assembly	3	62B	06767	Seal Ring	4
25	05778	Crosshead Assembly	3	64	07204-0100	Steel Ring	2
28	05779	Crosshead Pin	3	65	06588	Screw-In Connector	2
29A	07408	Hexagon Nut	1	66	06768	Threaded Elbow	2
29B	05383	Bracket 2 f. Cooling Hose	2	67	06769	Curved Leakage Pipe	2
29C	05662	Fixing Bracket	1	68	05782	Bottom Casing for Gear	1
29D	05381	Bracket 2 f. Cooling Hose	1	69	05783	Top Casing for Gear	1
30	07619	Cover Plate	1	70	05784	Gear Seal	1
30A	07225-0100	Hexagon Screw	9	71	05785	Centering Ring	1
30B	13136	Grommet	4	72A/B	03366	Gear Wheel Set, 1=2.25	1
30C	05053	Disc	8	72A/B	05786	Gear Wheel Set, 1=2.44	
30D	13154	Cover	1	72A/B	04670	Gear Wheel Set, 1=2.73	1
31	07623	Eye Bolt	1	74	05787	Self-Aligning Roller Bearing	1
32	07624	Radial Shaft Seal	3	75	05700	Cylinder Roller Bearing	1
33	07626	Seal Retainer	3	76	07117	Fitting Disc, 0.1 mm	1-5
33A	07627	O-Ring for Seal Retainer	3	77	05789	Radial Shaft Seal Ring	1
33B	07628	Circlip for 33	3	78	05665	Cylindrical Pin	6
33C	07249	Fitting Disc	3	80	05790	Spacer Ring 1 for Gear	1
34	13137	Oil Scraper (Flinger)	3	81	05791	Spacer Ring 2 for Gear	1
36	06748	Plunger	3	82	05802	Fixing Plate for Gear	1
38	06749	Seal Sleeve	3	83	13358	Hexagon Screw	1
38A	22764	Serrated Pin	3	84	05792	Hexagon Socket Screw	7
38B	06750	Leakage Gasket	3	85	05702	Hexagon Socket Screw	3
38C	06667	O-Ring	3	86	07159	Washer	3
39	05522	Seal Case	3	87	05793	Hexagon Socket Screw	5
39A	05523	O-Ring	6	88	05655	Hexagon Socket Screw	1
40	07338	Tension Spring	3	89	05794	Gear Flange, Hollow	1
41	06753	Support Disc	3	89A	05795	Centering Ring, Hollow	1
42	06754	Spiral Ring (Packing)	6	90	05796-180	Oil Cooler Assembly (K1-K20)	1
43	06755	Support Ring	6	K1	05797	Cooling Vane Plate	1
44	06756	Guide Ring	3	K2	05798	Seal for Gear Cover	2
45	06757	Pressure Ring	3	K3	05799	Gear Cover	1
46	13390	Seal Ring	3	K4	05029	Hexagon Head	
47	06758	Spacer Disc	3			Countersunk Screw	4
48	5524	Circlip	3	K5	05800	Hexagon Socket Screw	8
49	13159	Stud Bolt	8	K6	06725	Spring Washer	8
49A	13160	Hexagon Nut	8	K7	05755	Connection for Oil Cooler	1
50A	13162	Centering Stud	2	K8	06272	Copper Seal	5
50B*	06759-NPT	Valve Casing Assembly (50B-E)	1	K9	07109	Plug, 1/2" BSP	2
50C	03397	Connection Nipple, 1/2" NPT	1	K10	05031	Reducing Nipple	2
50D	03398	Lens Gasket	2	K11	05032	U-Joint Connector with Nut	3
50E	03399	Plug, 3/4" BSP	1	K12	05033	Tube for Cooler	2
51	05780	Inlet Valve Assembly (51B-51F)	3	K13	05402	Hose Clamp	4
51B	05193	O-Ring	3	K14	05403	Hose Guard	2
51C	05194	Inlet Valve Seat	3	K16	05405	Flat Gasket	3
51D	06761	Valve Plate	3	K17	08280	Washer	4
				K18	04158	Hexagon Socket Screw	4
				K19	04326	Elbow	1
				K20	04327	Hose Nipple	1

\*If the valve casing (50B) needs to be replaced, items 50C-E will be included

## GP7522GBHS-180 REPAIR KITS

### Plunger Packing Kit #09701

Item	Part #	Description	Qty.
38B	06750	Leakage Gasket	3
38C	06667	O-Ring	3
39A	05523	O-Ring	6
42	06754	Spiral Ring (Packing)	6
43	06755	Support Ring	6
44	06756	Guide Ring	3
46	13390	Seal Ring	3

### Oil Seal Kit #09221

Item	Part #	Description	Qty.
32	07624	Radial Shaft Seal	3
33A	07627	O-Ring	3

### Inlet Valve Assembly Kit #09702

Item	Part #	Description	Qty.
51B	05193	Support Ring	3
51C	05194	Inlet Valve Seat	3
51D	06761	Valve Plate	3
51E	06762	Valve Spring	3
58A	07700	O-Ring	3
58B	07693	Support Ring	3

### Discharge Valve Assembly Kit #09703

Item	Part #	Description	Qty.
52B	05193	O-Ring	3
52C	05195	Valve Seat	3
52D	06761	Valve Plate	3
52E	06762	Valve Spring	3
58A	07700	O-Ring	3
58B	07693	Support Ring	3

## GP7522GBHS-180 TORQUE SPECIFICATIONS

Position	Item #	Description	Lubrication Info	Torque Specifications
1	05769	Crankcase	Molycotec Cu-Paste	
17	05642	Inner Hexagon Screw		33 ft.-lbs. (45 Nm)
24	05777	Connecting Rod Assembly		29.5 ft.-lbs. (40 Nm)
30A	07225-0100	Hexagon Screw		88.5 in.-lbs. (10 Nm)
32	07624	Radial Shaft Seal	Loctite 403	
49	13159	Stud Bolt	Loctite 243	
49A	13160	Hexagon Nut		59 ft.-lbs. (80 Nm)
51C	05194	Inlet Valve Seat	Hylomar	
52C	05195	Discharge Valve Seat	Hylomar	
58C	07702	Hexagon Screw		155 ft.-lbs. (210 Nm)
85	05702	Hexagon Socket Screw		75.2 in.-lbs. (8.5 Nm)
K2	05798	Seal for Gear Cover	Loctite 5910	
K5	05800	Hexagon Socket Screw		33 ft.-lbs. (45 Nm)
K9	07109	Plug, 1/2" BSP		59 ft.-lbs. (80 Nm)
K18	04158	Hexagon Socket Screw		124 in.-lbs. (14 Nm)

# GP7522GBHS-180 REPAIR INSTRUCTIONS

**CAUTION:** Don't loosen the 3 plunger (36) before the valve casing has been removed otherwise the plunger (36) could hit against the spacer pipe (51F) when the pump is being turned.

**NOTE:** Always take time to lubricate all metal and non-metal parts with a light film of oil before reassembling. This step will help ensure proper fit, at the same time protecting the pump non-metal parts (elastomers) from cutting and scoring.

## TO CHECK VALVES



1) Loosen and remove screws (58C) with a 24mm socket wrench.

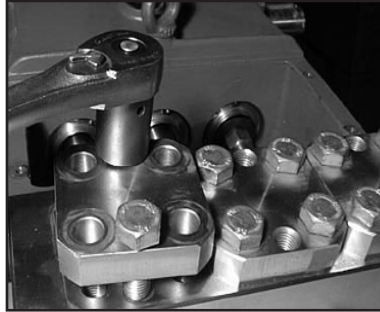

2) Take plugs (58) out of valve casing (50) by tightening screws (58C) against valve casing with two screws.

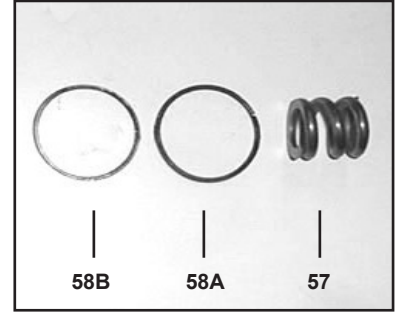

3) Remove the compression spring (57) O-Ring (58A) and support ring (58B).



4) Take out valve assemblies (52 & 51) using either tool (part #07662) or a stud bolt.

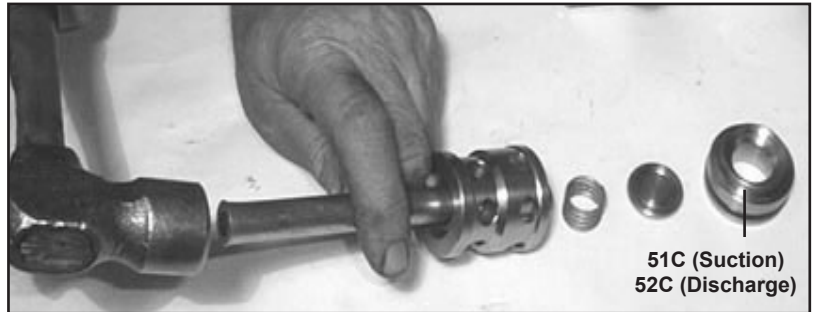

5) Valve seats (51C and 52C) are pressed out of spacer pipes (51F and 52F) by hitting the valve plates (51D and 52D) with a socket extension.

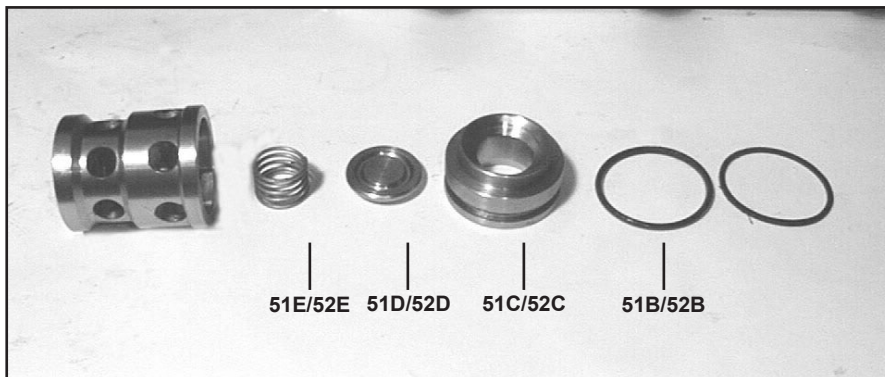

6) Check surfaces of valve plates (51D and 52D), valve seats (51C or 52C) and o-rings (51B and 52B). Replace worn parts.

# GP7522GBHS-180 REPAIR INSTRUCTIONS

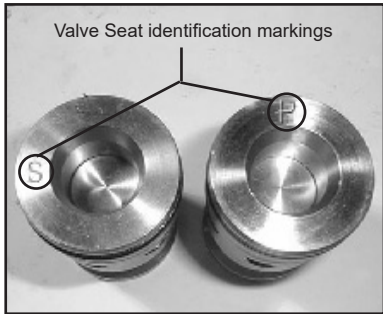

- 7) When reassembling: The inlet valve seat (51C) is 1mm smaller in diameter than the discharge valve seat (52C). Inlet valve seats are marked "S" and always have to be installed first. Discharge valve seats are marked "P" and are always to be installed on top of inlet valve. Plugs (58) are to be tensioned down evenly with screws (58C) and in crosswise pattern at 155 ft.lbs. (210 N-m).

## TO CHECK SEALS

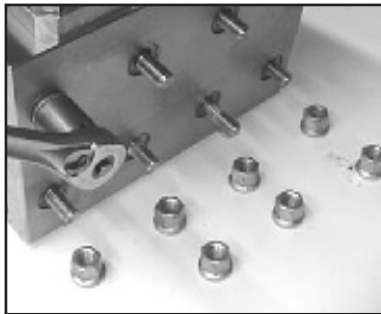

- 8) Loosen nuts (49A) with a 24mm socket wrench.

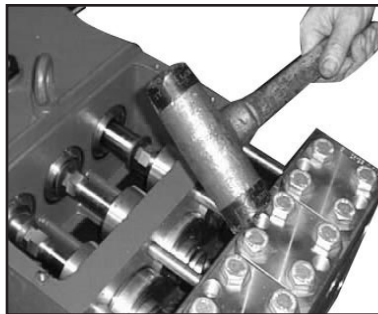

- 9) With a rubber mallet tap the back of the valve casing (50) and pull the valve casing off the stud bolt (49).



- 10) Remove cover plate (30) with a 10mm socket wrench.



- 11) By gripping hex flats, separate plunger (36) from cross-head (25) by means of two open-end wrenches (size 22mm and 27mm).

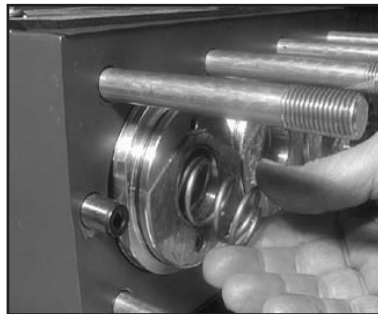

- 12) Remove tension spring (40) from seal retainer (38).

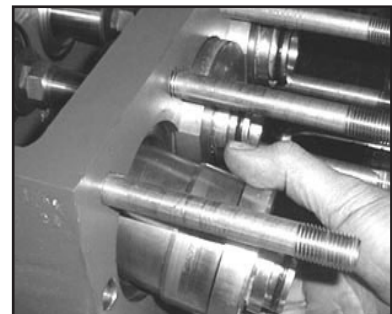

- 13) Pull seal sleeves (38) and plungers (36) out of their fittings in the crankcase (1) using ring groove as a guide.



## GP7522GBHS-180 REPAIR INSTRUCTIONS

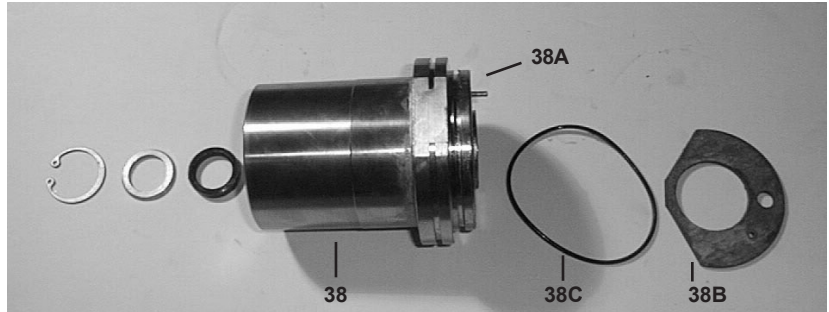
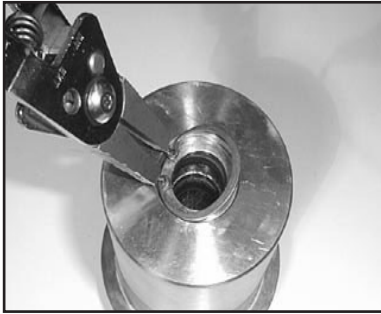

14) Remove circlip ring (48) from seal sleeve (38). Remove spacer disc (47) and seal ring (46) from seal sleeve. Replace worn or damaged parts.

15) Remove leakage gasket (38B) from serrated pin (38A) on the seal sleeve (38). Check o-ring (38C) for damage and replace if necessary. **IMPORTANT!** The 3.2 mm (diameter bore of the leakage gasket (38B) must be inserted directly on the serrated pin (38A) of the seal sleeve (38). The leakage gasket must fit snugly to the seal so that the bevelled surface of the gasket faces outwards.

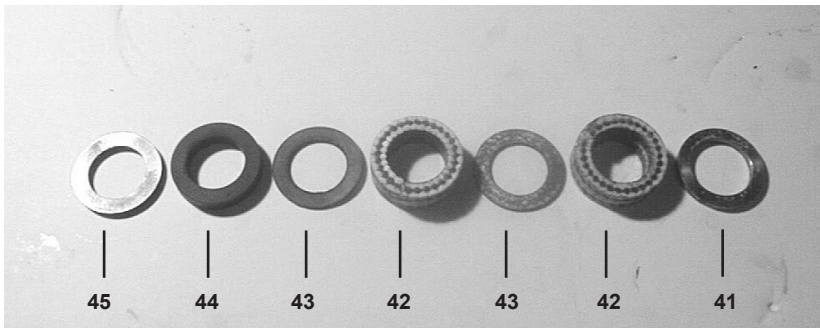

16) Remove support disc (41) seal unit (42, 43, 44) and pressure ring (45) of seal sleeve (38). Examine seals for signs of wear or cavitation, and if necessary, replace.

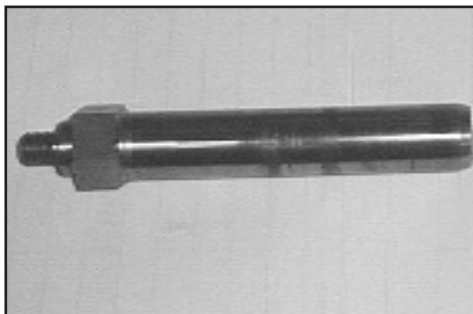

17) Examine plunger (36) for signs of wear or cavitation. If the surface of the plunger is worn, screw out the plunger with a 27mm tool. Clean centering and front surface of crosshead with plunger (25). Thread new plunger carefully through oiled seals in seal sleeve. Coat thread of new plunger lightly with bonding agent (e.g., loctite).

**NOTE:** Seal life can be increased if the pre-tensioning allows for a little leakage. This assists lubrication and keeps the seals cool. It is therefore not necessary to replace seals before the leakage becomes too heavy and causes output and operating pressure to drop.

# GP7522GBHS-180 REPAIR INSTRUCTIONS

## TO ASSEMBLE VALVE CASING

18. Check O-rings (39A) and support rings (39B) on seal case (39). Clean surfaces of seal sleeves (38) in crankcase (1) and sealing surfaces of valve casing (50). Insert seal sleeve with plunger into crankcase guide. Turn crankshaft to (22) until plunger with crosshead (25) pushes against plunger tighten plunger (36) to 33 ft-lbs (45 N-m).

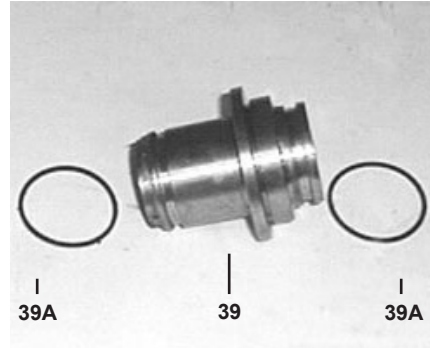

19. Push valve casing carefully over O-rings of seal case and centering studs (50A). Tighten nuts (49A) to space 103 ft-lbs (140 N-m).

## TO DISMANTLE REDUCTION GEAR

Remove screws (K4). Remove the gear cover (K2). It may be necessary to tap the cover off with a rubber mallet. Remove screw (K11) and take off the spacer ring (K7) and tension disc (K10). Push the cogwheel (K9) off the shaft by screwing two screws into both thread bores. Unscrew hexagon screws (10) and remove the shaft cover (21) and bearing cover (14). Finally, take the crankshaft (22) out of the crankcase by tapping it towards the bearing cover side, opposite the gearbox, using a rubber hammer.

Check the surfaces of connecting rods (24), crankshaft (22) and crossheads (25). Check the surfaces of the crosshead guides in the crankcase for any unevenness.

Reassemble in reverse order. Regulate axial bearing clearance to a minimum of 0.1mm and a maximum 0.15mm by means of fitting discs (20A). Insert the crankshaft by passing it through on the bearing cover side. Press in the outer bearing ring (20). The crankshaft should turn easily and with little clearance. Fit the bearing cover (14) and tighten screws (24) to 30 ft.-lbs. (40 Nm).

**Important!** The connecting rod has to be able to slightly move sidewise at the crankshaft journal.

Heat the ball bearings (K13) before pressing them onto the pinion (K12). Slightly press the cogwheel (K9) onto the crankshaft, so that the pinion (K12) together with the bearing (K13) can still be inserted.

When mounting, place the pinion (K12) onto the cogwheel so that they correctly interlock. Carefully tap the cogwheel and the pinion simultaneously onto the crankshaft and into the bearing seat.

Fit tension disc (K10), and spacer ring (K7) and tighten screw (K11) with Loctite.

Fit seal (K14) on to the cylindrical pins (K3).

Push the gear cover (K2) carefully on to the bearing (K13). Make sure the radial shaft seal (K17) does not get damaged during fitting on to the pinion.

**Important!** Before putting into operation again, turn the reduction gear shaft by hand at least four full turns to make sure that the gear is correctly aligned.

**GP7522GBHS-180 Dimensions - Inches (mm)**

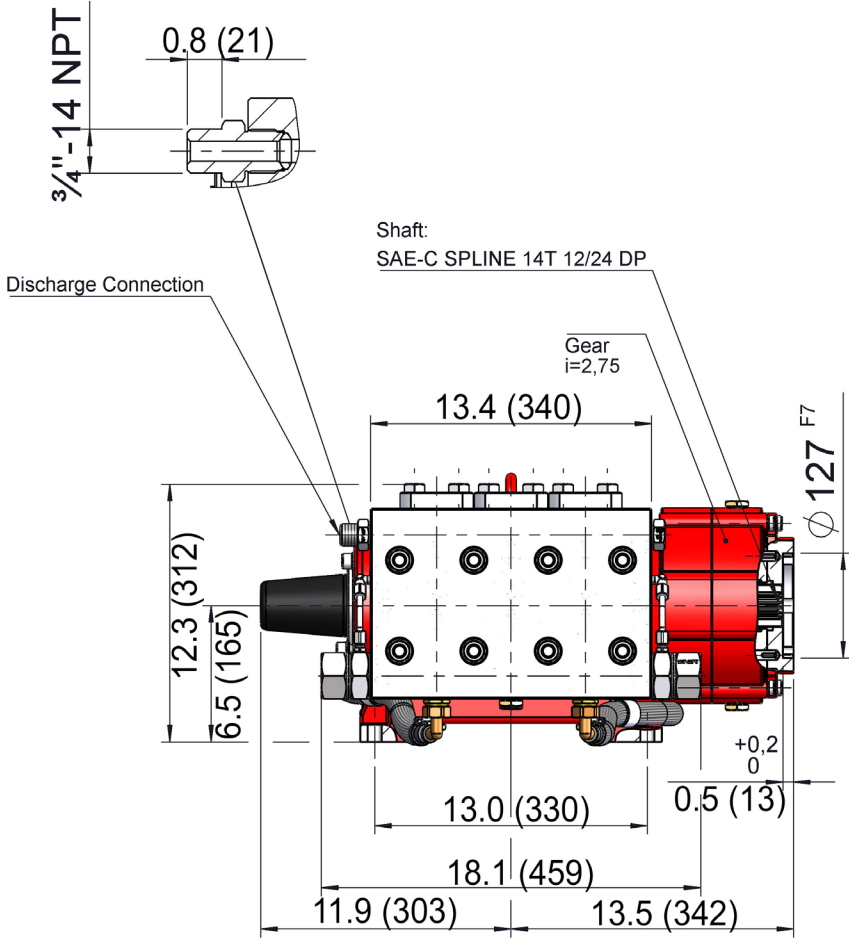
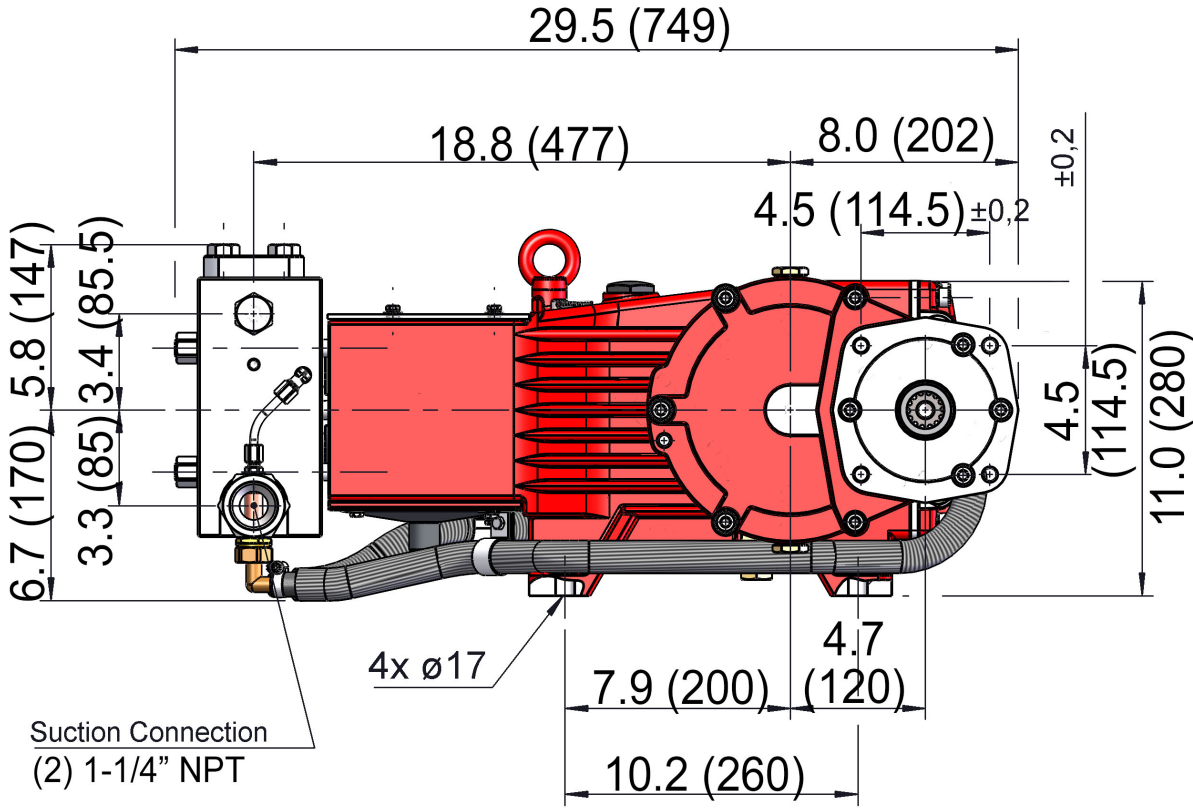

## GIANT INDUSTRIES LIMITED WARRANTY

Giant Industries, Inc. pumps and accessories are warranted by the manufacturer to be free from defects in workmanship and material as follows:

1. Five (5) years from the date of shipment for all pumps used in portable pressure washers with NON-SALINE, clean water applications.
2. Two (2) years from the date of shipment for Giant pumps used in car wash applications.
3. One (1) year from the date of shipment for all other Giant industrial and consumer pumps.
4. Six (6) months from the date of shipment for all rebuilt pumps
5. Ninety (90) days from the date of shipment for all Giant accessories.

This warranty is limited to repair or replacement of pumps and accessories of which the manufacturer's evaluation shows were defective at the time of shipment by the manufacturer. The following items are NOT covered or will void the warranty:

1. Defects caused by negligence or fault of the buyer or third party.
2. Normal wear and tear to standard wear parts.
3. Use of repair parts other than those manufactured or authorized by Giant.
4. Improper use of the product as a component part.
5. Changes or modifications made by the customer or third party.
6. The operation of pumps and or accessories exceeding the specifications set forth in the Operations Manuals provided by Giant Industries, Inc.

Liability under this warranty is on all non-wear parts and limited to the replacement or repair of those products returned freight prepaid to Giant Industries which are deemed to be defective due to workmanship or failure of material. A Returned Goods Authorization (R.G.A.) number and completed warranty evaluation form is required prior to the return to Giant Industries of all products under warranty consideration. Call (419)-531-4600 or fax (419)-531-6836 to obtain an R.G.A. number.

Repair or replacement of defective products as provided is the sole and exclusive remedy provided hereunder and the MANUFACTURER SHALL NOT BE LIABLE FOR FURTHER LOSS, DAMAGES, OR EXPENSES, INCLUDING INCIDENTAL AND CONSEQUENTIAL DAMAGES DIRECTLY OR INDIRECTLY ARISING FROM THE SALE OR USE OF THIS PRODUCT.

THE LIMITED WARRANTY SET FORTH HEREIN IS IN LIEU OF ALL OTHER WARRANTIES OR REPRESENTATION, EXPRESS OR IMPLIED, INCLUDING WITHOUT LIMITATION ANY WARRANTIES OR MERCHANTABILITY OR FITNESS FOR A PARTICULAR PURPOSE AND ALL SUCH WARRANTIES ARE HEREBY DISCLAIMED AND EXCLUDED BY THE MANUFACTURER.



**WARNING:** This product might contain a chemical known to the State of California to cause cancer, and birth defects or other reproductive harm.  
For more information go to [www.P65Warnings.ca.gov](http://www.P65Warnings.ca.gov)

**GIANT**  
Performance Under Pressure

**GIANT INDUSTRIES, INC.**  
900 N. Westwood Ave., Toledo, Ohio 43607  
Phone: (419)-531-4600 FAX (419)-531-6836  
[www.giantpumps.com](http://www.giantpumps.com)  
© Copyright 2023 Giant Industries, Inc.