

Models

GP7645/GP7650/GP7655

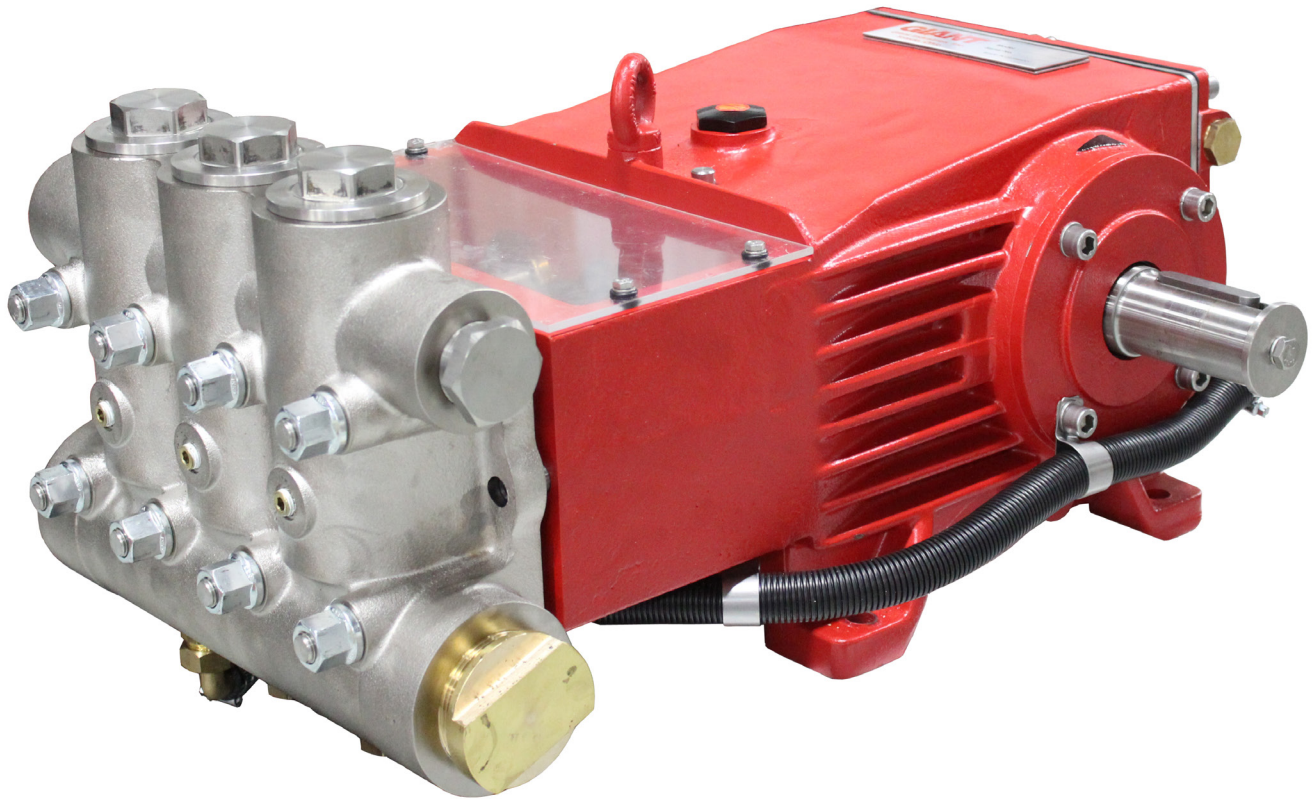

Contents:

Installation Instructions:	page 2
Pump Specifications:	page 3
Dimensions:	page 3
Exploded View:	page 4
Parts List:	page 5
Kits:	page 6
Torque Specifications:	page 6
Maintenance Information:	page 6
Repair Instructions:	page 7
Warranty Information:	back page

INSTALLATION INSTRUCTIONS

Performance

	Power Required	Pressure	Max. Speed	Max. Flow	Max. Temp.	Plunger ø	Plunger Stroke	Weight	NPSHR
Model	BHP (kW)	PSI (bar)	RPM	GPM (l/min)	°F (°C)	in (mm)	in (mm)	lbs. (kg)	ft. of head (mWs)
GP7645	115 (82.5)	3000 (200)	800	55.5 (210)	86 (30)	1.77 (45)	2.28 (58)	408 (185)	29.8 (9.1)
GP7650	122 (90)	2500 (175)	800	69.7 (264)	86 (30)	1.97 (50)	2.28 (58)	408 (185)	30.5 (9.3)
GP7655	117 (88)	2000 (140)	800	84.5 (320)	86 (30)	2.17 (55)	2.28 (58)	408 (185)	32.1 (9.8)

1) Figures given for maximum pressure and maximum speed (rpm) apply to intermittent operation with cold water.

Definition of intermittent operation:

Operation at full performance for not more than altogether 20 minutes an hour, with the pump running without pressure or turned off inbetween.

For example, this can be full load operation for 5 minutes four times an hour with 10 minute breaks inbetween or continuous full load operation for 20 minutes followed by a 40 minute break.

2) Higher water temperatures are possible with a separate external crankcase cooling system.

The manufacturer is to be contacted in this case.

3) The max. pressure is to be reduced by 10% where continuous operation with a cooler (with or without gear) is involved.

NPSHR / Inlet pressure

Required NPSH refers to water (at 20°C) at max. permissible pump speed.



The suction side input pressure must not exceed 29 PSI (2 bar) if the integrated gear oil cooling system is connected.

The max. system pressure for a separately fitted oil cooling system must likewise not exceed 29 PSI (2 bar).

If the integrated gear oil cooling system is not used, the max. admissible input pressure on the pump suction side is 29 PSI (2 bar). In this case, transmitted pulsation from the pump to the suction line must be sufficiently damped.

Level of noise emission

Emission sound pressure level: ≤ 94 dB(A)

Fields of application

The fields of application of these pump types correspond to the specifications in the assembly instructions Giant Industries.

Ambient conditions

Ambient temperature: $41\text{ °F} < T_{\text{Amb.}} < 86\text{ °F}$

Ambient temperature: $5\text{ °C} < T_{\text{Amb.}} < 30\text{ °C}$

Oil filling

- Filling quantities
 - Pump without gear with oil cooler 1.6 gal (6.0 l)
 - Pump without gear without oil cooler 1.9 gal (7,2 l)
- Quality: Industrial gear oil ISO VG 220 or automotive gear oil SAE 90 GL4 (Giant's p/n 01154)
- Intervals: first oil change after 50 operating hours, then every 1000 operating hours, but at the latest after 12 months.



If the pump is mounted on a vehicle (possible inclined position during operation) and/or if the pump speed is between 300 rpm and 500 rpm, the required oil quantity increases by 0.26 gal (1 liter).

Installation/ Putting into Operation

Shaft protector

When the pump is in operation, the open shaft end must be covered up by shaft protector (21), the driven shaft side and coupling by a contact-protector and the plunger room by cover (30).

Direction of pump rotation

An arrow on the pump crankcase indicates the recommended direction of rotation for the drive shaft.

The indicated direction ensures that oil is correctly distributed on and into the crosshead guides via optimal conrod motion thus providing best possible lubrication particularly with regard to continuous operation.

Reduction gears can be fitted on the left or right side and at different angles to accommodate the recommended rotational direction thus facilitating planning and fitting of pump units.

Suction line filter

Recommended mesh size 150 µm.

Gear oil cooling

The GP7600 pump series can alternatively be equipped with a gear oil cooling system.



The pumps can be run without gear oil cooling in continuous operation up to a power rating of 80 HP (60 kW) or with major intermittent operation at full performance.

If operational power exceeds 60 kW or for pumps fitted with a flanged reduction gear, this oil cooling system is recommended.

The cooling system works independently using the conveyed water during pump operation. A part of the water drawn by the plunger goes through a pipe and to a cooler plate in the drive casing. The flow amount in the cooling system therefore depends on the plunger diameter and the pump rpm. The amount of conveyed cooling water ensures satisfactory oil cooling under observation of maximum admissible pump rpm limits.

The temperature of the pumped water should not exceed 86 °F (30 °C).



If higher medium temperatures or liquids other than water are involved or aggressive media such as seawater, demineralised water etc the integrated gear oil cooling system must be decoupled and a separate cooling circuit set up.

The separate cooler must have a cooling efficiency of 1500 watt.

If there is a danger of frost, an appropriate amount of antifreeze must be mixed into the cooling circuit.

Operation



The pump and cooling system must be emptied if there is a danger of frost. Note that travel wind, for example, can cause water in pumps fitted on open vehicles to freeze even if the outside temperature is above freezing point.

Empty the pump through the second unused suction and discharge connection using compressed air, for example. Bottom plugs (12) on the suction channel can be opened as well.

The pump can also be run "dry" for 1-2 minutes to aid emptying.

Empty the cooling system by removing screw joints (K11) on the pump head and by blowing the hoses with compressed air on the (K11/K7) side.

Anti-freeze is recommended to guard against frost where a separate cooling circuit is used.

Maintenance and Servicing

For the type of threadlocker used and the required tightening torques, observe the table in the exploded view.

Special tools required

The following special tools are required for assembly:

- Extraction tool (p/n 07662)
- Pull-out tool size 5
- Snap-ring tongs

Suction and Discharge Valves

Screw off plugs (58).

Take out tension spring (57).

Remove the complete valve (51, 52) and valve holder (55) using either a valve tool or an M16 hexagon screw.

To dismantle valves:

Screw valve seat (51E, 52E) out of spring tension cap (51A, 52A).

Check sealing surfaces and replace worn parts.

Check O-rings and support rings.

Tighten plugs (58) to the required torque.



If worn, the discharge valve seat (52E) can be turned 180° round and refitted.

Seals and Plunger

Loosen nuts (49A) and remove pump head.

Separate plunger connection (36A) from crosshead (25) by means of an open-end wrench (size 36).

Pull seal sleeves (39) out of their fittings in the crankcase.

Take seal case (38) out of seal sleeve (39) and remove tension spring (45) (GP7645/GP7650).

Take seal unit (40,41,42,43 – P76/320) or (41,42,43 – GP7645/GP7650) out of the seal sleeve.

Examine plunger pipe (36B) and seals (39A, 42) and O-rings (38A, 38B) or (41 – P76/320).

Worn parts to be replaced.

When replacing plunger pipe (36B), tighten tension screws (36C) to the required torque.

Replace worn parts; grease seals with Silicone before installing.



Always remove the valve casing first before taking the 3 plungers (36) off the crossheads (25).

Otherwise the plunger (36) could hit against the spring tension cap (51A) and valve holder (55) when turning the pump

The service life of the seals is maximized if a minimal amount of leakage is present.

A few drops of water can drip from each plunger every minute.

Leakage has to be examined every day; the plunger seals must be changed should leakage become excessive (=constant dripping).

Seal life can be increased if the pretensioning allows for a little leakage.

This assists lubrication and keeps the seals cool.

It is therefore not necessary to replace seals before the leakage becomes too heavy and causes output and operating pressure to drop.

When reassembling, tighten plunger screws (36A) to the required torque.

Mounting Valve Casing:

Examine the O-rings (38A, 38B) on seal cases (38).

Clean the seal sleeve contact surfaces in the crankcase and the sealing surfaces in the valve casing.

Carefully push the valve casing onto the seal case O-rings and centring studs (50A).

Tighten nuts (49A) to the required torque.

If required, supplementary assembly instructions can be requested from the manufacturer Giant Industries.

Exploded View - GP7645, GP7650 & GP7655

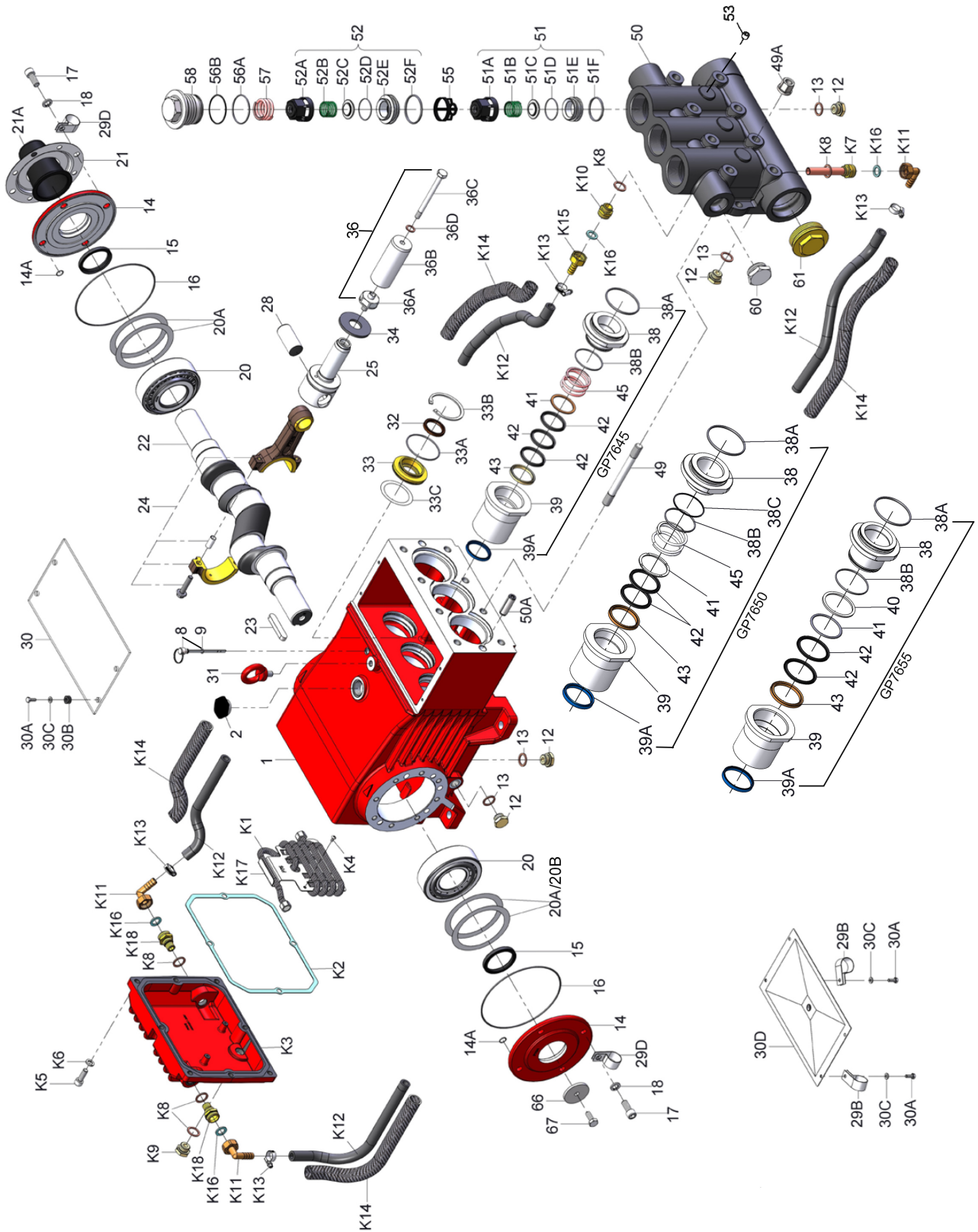

GP7645, GP7650 & GP7655 Spare Parts List

<u>ITEM</u>	<u>PART</u>	<u>DESCRIPTION</u>	<u>QTY.</u>	<u>ITEM</u>	<u>PART</u>	<u>DESCRIPTION</u>	<u>QTY.</u>
1	05769	Crankcase	1	42	13294	V-Sleeve, GP7645	9
2	13000	Oil Filler Plug Assembly	1	42	07638	V-Sleeve, GP7650	6
8	07603	Oil Dip Stick	1	42	07711	V-Sleeve, GP7655	6
9	01009	O-Ring, Dip Stick	1	43	13293	Pressure Ring, GP7645	3
12	07109	Drain Plug	7	43	07639	Pressure Ring, GP7650	3
13	06272	Copper Seal for 12	7	43	07712	Pressure Ring, GP7655	3
14	05770	Bearing Cover	2	45	13297	Tension Spring, GP7645	3
14A	12204	O-Ring	8	45	07636	Tension Spring, GP7650	3
15	05771	Radial Shaft Seal	2	49	13159	Stud Bolt	8
16	05772	O-Ring	2	49A	13160	Hexagon Nut	8
17	05642	Inner Hexagon Screw	8	50	07791	Valve Casing	1
18	05039	Spring Ring	8	50A	13162	Centering Stud	2
20	05773	Taper Roller Bearing	2	51	05594	Inlet Valve Assembly (51A-51F)	3
20A	05774	Fitting Disc (Shim), 0.1 mm	1-5	51A	05595	Spring Tension Cap	3
20B	04570	Fitting Disc (Shim), 0.15 mm	1-5	51B	05450	Valve Spring	3
21	05645	Shaft Guard Holder	1	51C	05247	Valve Plate	3
21A	05646	Shaft Guard	1	51D	05596	O-Ring	3
22	04517A	Crankshaft	1	51E	05597	Inlet Valve Seat	3
23	07614	Key	1	51F	05166	O-Ring	3
24	05777	Connecting Rod Assembly	3	52	05600	Discharge Valve Assembly	3
25	05778	Crosshead Assembly	3	52A	05595	Spring Tension Cap	3
28	05779	Crosshead Pin	3	52B	05450	Valve Spring	3
29B	05383	Bracket 2 f. Cooling Hose	2	52C	05247	Valve Plate	3
29D	05381	Bracket 2 f. Cooling Hose	2	52D	05596	O-Ring	3
30	07619	Cover Plate	1	52E	05598	Discharge Valve Seat	3
30A	07225-0100	Hexagon Screw	8	52F	05599	O-Ring	3
30B	13136	Grommet	4	53	22610	Plug, 1/4" NPT	3
30C	08280	Disc	8	55	05647	Valve Spacer	3
30D	13154	Cover	1	56A	07658	O-Ring	3
31	07623	Eye Bolt	1	56B	07635	Support Ring	3
32	07624	Radial Shaft Seal	3	57	13173	Tension Spring	3
33	07626	Seal Retainer	3	58	06682	Plug, M64 x 2	3
33A	07627	O-Ring for Seal Retainer	3	60	12251	Plug, 1-1/4" NPT	1
33B	07628	Circlip for 33	3	61	05170	Plug, 2-1/2" NPT	1
33C	07249	Fitting Disc	3	66	13362	Disc for Crankshaft	1
34	13137	Oil Scraper (Flinger)	3	67	13358	Hexagon Screw	1
36	06165A	Plunger Assy. (36A-36D), GP7645	3	90	03704	Oil Cooler Assembly	1
36	07630	Plunger Assy. (36A-36D), GP7650	3	K1	03705	Stainless Steel Tubing	1
36	07706	Plunger Assy. (36A-36D), GP7655	3	K2	03708	Gear Cover Seal	1
36A	07667	Plunger Connection	3	K3	03709	Gear Cover	1
36B	05157A	Plunger Pipe, GP7645	3	K4	03710	Clamping Screw	2
36B	07793	Plunger Pipe, GP7650	3	K5	22706	Hexagon Socket Screw	8
36B	07666	Plunger Pipe, GP7655	3	K6	06725	Washer	8
36C	07664	Tensioning Screw	3	K7	05755	Connection for Oil Cooler	1
36D	07665	Copper Ring	3	K8	06272	Copper Seal	5
38	06167	Seal Case, GP7645	3	K9	07109	Plug, 1/2" BSP	1
38	07794	Seal Case, GP7650	3	K10	05031	Reducing Nipple	1
38	13155	Seal Case, GP7655	3	K11	05032	U-Joint Connector with Nut	3
38A	13156	O-Ring	3	K12	05033	Tube for Cooler	1.4 m
38B	06258	O-Ring, GP7645/GP7650	3	K13	05402	Hose Clamp	4
38B	07721	O-Ring, GP7655	3	K14	05403	Hose Guard	1.3 m
38C	07635	Support Ring, GP7650	3	K15	05404	Hose Coupling Nut	1
39	06171	Seal Sleeve, GP7645	3	K16	05405	Flat Gasket	4
39	07795	Seal Sleeve, GP7650	3	K17	03706	Hose Plate	1
39	13157	Seal Sleeve, GP7655	3	K18	03707	Reduction Nipple	2
39A	13290	Grooved Ring, GP7645	3		07662	Valve Tool (not shown)	1
39A	07796	Grooved Ring, GP7650	3		17498	Gear Assembly (4x12-13, 34,49,49A,50,50A,66,67)	
39A	07723	Grooved Ring, GP7655	3			Manifold Assembly	
40	07797	Support Ring, GP7655	3	05210A		Plunger Conversion Kit GP7645	
41	13296	O-Ring, GP7645	3	04296		Plunger Conversion Kit GP7650	
41	05318	Sleeve Support Ring, GP7650	3	05211		Plunger Conversion Kit GP7655	
41	13158	O-Ring, GP7655	3				

Repair Kits - GP7645, GP7650 & GP7655

Plunger Packing Kit, GP7645 - # 09603

Item	Part #	Description	Qty.
38A	13156	O-Ring	3
38B	06258	O-Ring	3
39A	13290	Grooved Ring	3
42	13294	V-Sleeve	9

Plunger Packing Kit, GP7650 - # 09526

Item	Part #	Description	Qty.
38A	13156	O-Ring	3
38B	06258	O-Ring	3
38C	07635	Support Ring	3
39A	07796	Grooved Ring	3
42	07638	V-Sleeve	6

Plunger Packing Kit, GP7655 - # 09220

Item	Part #	Description	Qty.
38A	13156	O-Ring	3
38B	07721	O-Ring	3
39A	07723	Grooved Ring	3
41	13158	Support Ring	3
42	07711	V-Sleeve	6

Oil Seal Kit - # 09221

Item	Part #	Description	Qty.
32	07624	Radial Shaft Seal	3
33A	07627	O-Ring	3

Inlet Valve Kit - # 09659

Item	Part #	Description	Qty.
51	05594	Inlet Valve Assembly	1
56A	07658	O-Ring	1
56B	07635	Support Ring	1

Large Discharge Valve Kit - # 09660

Item	Part #	Description	Qty.
52	05600	Discharge Valve Assy	1
55	05647	Valve Spacer	1
56A	07658	O-Ring	1
56B	07635	Support Ring	1

Small Discharge Valve Kit* - # 09661

Item	Part #	Description	Qty.
51B	05450	Valve Spring	1
51C	05247	Valve Plate	1
51D	05596	O-Ring	1
52F	05599	O-Ring	1
56A	07658	O-Ring	1
56B	07635	Support Ring	1

* The discharge valve seat (item 52E) can be flipped over and used. If it is damaged on both sides, order kit # 09660.

GP7645, GP7650 & GP7655 Torque Specifications

Position	Thread	Lubrication Info	Torque Specifications
1		Molycote Cu-Paste	
12	1/2" BSP		29.5 ft.-lbs. (40 Nm)
15		Loctite 403	
17	M12		64 ft.-lbs. (87 Nm)
24	M10		29.5 ft.-lbs. (40 Nm)
32		Loctite 403	
36A			33 ft.-lbs. (45 Nm)
36C	M10	Loctite 243	29.5 ft.-lbs. (40 Nm)
39		Copper Paste Crankcase Side	
49		Loctite 648	
49A	M16		133 ft.-lbs. (180 Nm)
51E		Hylomar	
52E		Hylomar	
58	M64x2		107 ft.-lbs. (145 Nm)
K4	M5		
K5	M10		33 ft.-lbs. (45 Nm)
K9	1/2" BSP		29.5 ft.-lbs. (40 Nm)
K18	1/2" BSP	Loctite 243	29.5 ft.-lbs. (40 Nm)

GP7645, GP7650 & GP7655 Dimensions - Inches (mm)

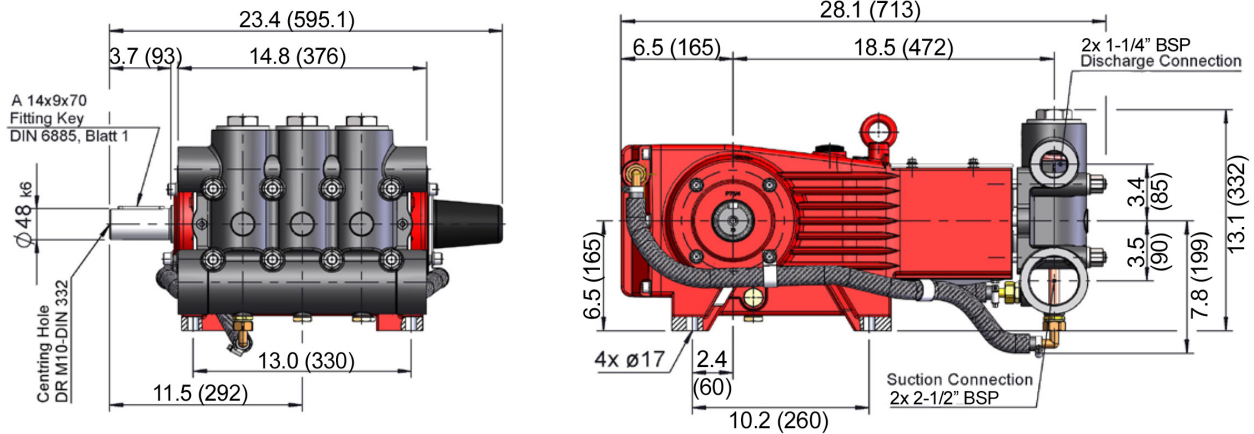

GIANT INDUSTRIES LIMITED WARRANTY

Giant Industries, Inc. pumps and accessories are warranted by the manufacturer to be free from defects in workmanship and material as follows:

1. Five (5) years from the date of shipment for all pumps used in portable pressure washers with NON-SALINE, clean water applications.
2. Two (2) years from the date of shipment for Giant pumps used in car wash applications.
3. One (1) year from the date of shipment for all other Giant industrial and consumer pumps.
4. Six (6) months from the date of shipment for all rebuilt pumps
5. Ninety (90) days from the date of shipment for all Giant accessories.

This warranty is limited to repair or replacement of pumps and accessories of which the manufacturer's evaluation shows were defective at the time of shipment by the manufacturer. The following items are NOT covered or will void the warranty:

1. Defects caused by negligence or fault of the buyer or third party.
2. Normal wear and tear to standard wear parts.
3. Use of repair parts other than those manufactured or authorized by Giant.
4. Improper use of the product as a component part.
5. Changes or modifications made by the customer or third party.
6. The operation of pumps and or accessories exceeding the specifications set forth in the Operations Manuals provided by Giant Industries, Inc.

Liability under this warranty is on all non-wear parts and limited to the replacement or repair of those products returned freight prepaid to Giant Industries which are deemed to be defective due to workmanship or failure of material. A Returned Goods Authorization (R.G.A.) number and completed warranty evaluation form is required prior to the return to Giant Industries of all products under warranty consideration. Call (419)-531-4600 or fax (419)-531-6836 to obtain an R.G.A. number.

Repair or replacement of defective products as provided is the sole and exclusive remedy provided hereunder and the MANUFACTURER SHALL NOT BE LIABLE FOR FURTHER LOSS, DAMAGES, OR EXPENSES, INCLUDING INCIDENTAL AND CONSEQUENTIAL DAMAGES DIRECTLY OR INDIRECTLY ARISING FROM THE SALE OR USE OF THIS PRODUCT.

THE LIMITED WARRANTY SET FORTH HEREIN IS IN LIEU OF ALL OTHER WARRANTIES OR REPRESENTATION, EXPRESS OR IMPLIED, INCLUDING WITHOUT LIMITATION ANY WARRANTIES OR MERCHANTABILITY OR FITNESS FOR A PARTICULAR PURPOSE AND ALL SUCH WARRANTIES ARE HEREBY DISCLAIMED AND EXCLUDED BY THE MANUFACTURER.



WARNING: This product might contain a chemical known to the State of California to cause cancer, and birth defects or other reproductive harm.

For more information go to www.P65Warnings.ca.gov