

GP7645GBHS, GP7650GBHS & GP7655GBHS Repair Instructions

Operation



The pump and cooling system must be emptied if there is a danger of frost. Note that travel wind, for example, can cause water in pumps fitted on open vehicles to freeze even if the outside temperature is above freezing point.

Empty the pump through the second unused suction and discharge connection using compressed air, for example. Bottom plugs (12) on the suction channel can be opened as well.

The pump can also be run "dry" for 1-2 minutes to aid emptying.

Empty the cooling system by removing screw joints (K11) on the pump head and by blowing the hoses with compressed air on the (K11/K7) side.

Anti-freeze is recommended to guard against frost where a separate cooling circuit is used.

Maintenance and Servicing

For the type of threadlocker used and the required tightening torques, observe the table in the exploded view.

Special tools required

The following special tools are required for assembly:

- Extraction tool (code no. 15.0038)
- Pull-out tool size 5
- Snap-ring tongs

Suction and Discharge Valves

Screw off plugs (58).

Take out tension spring (57).

Remove the complete valve (51, 52) and valve holder (55) using either a valve tool or an M16 hexagon screw.

To dismantle valves:

Screw valve seat (51E, 52E) out of spring tension cap (51A, 52A).

Check sealing surfaces and replace worn parts.

Check O-rings and support rings.

Tighten plugs (58) to the required torque.



If worn, the discharge valve seat (52E) can be turned 180° round and refitted.

Seals and Plunger

Loosen nuts (49A) and remove pump head.

Separate plunger connection (36A) from crosshead (25) by means of an open-end wrench (size 36).

Pull seal sleeves (39) out of their fittings in the crankcase.

Take seal case (38) out of seal sleeve (39) and remove tension spring (45) (GP7645).

Take seal unit (40,41,42,43 – GP7655) or (41,42,43 – GP7645/GP7650) out of the seal sleeve.

Examine plunger pipe (36B) and seals (39A, 42) and O-rings (38A, 38B) or (41 – GP7655).

Worn parts to be replaced.

When replacing plunger pipe (36B), tighten tension screws (36C) to the required torque.

Replace worn parts; grease seals with Silicone before installing.



Always remove the valve casing first before taking the 3 plungers (36) off the crossheads (25).

Otherwise the plunger (36) could hit against the spring tension cap (51A) and valve holder (55) when turning the pump.

The service life of the seals is maximized if a minimal amount of leakage is present.

A few drops of water can drip from each plunger every minute.

Leakage has to be examined every day; the plunger seals must be changed should leakage become excessive (=constant dripping).

Seal life can be increased if the pretensioning allows for a little leakage.

This assists lubrication and keeps the seals cool.

It is therefore not necessary to replace seals before the leakage becomes too heavy and causes output and operating pressure to drop.

When reassembling, tighten plunger screws (36A) to the required torque.

Mounting Valve Casing:

Examine the O-rings (38A, 38B) on seal cases (38).

Clean the seal sleeve contact surfaces in the crankcase and the sealing surfaces in the valve casing.

Carefully push the valve casing onto the seal case O-rings and centring studs (50A).

Tighten nuts (49A) to the required torque.

GP7645GBHS, GP7650GBHS & GP7655GBHS Repair Instructions

Mounting the Reduction Gear to the Crankcase

Remove the screws (10/11).

Take bearing cover (14) with its radial shaft seal and fitting key (23) off the crankcase.

Mount the casing bottom (68) together with O-ring (16) and centring ring (71) using the six screws (84).



The casing bottom (68) has threaded bores for fitting at 4 different angles of 90°.

The positioning of these flange bores onto the pump crankcase determines the position of the gear drive shaft. The gearbox drive shaft can be rotated 180° to the pump drive shaft. See sketch below.

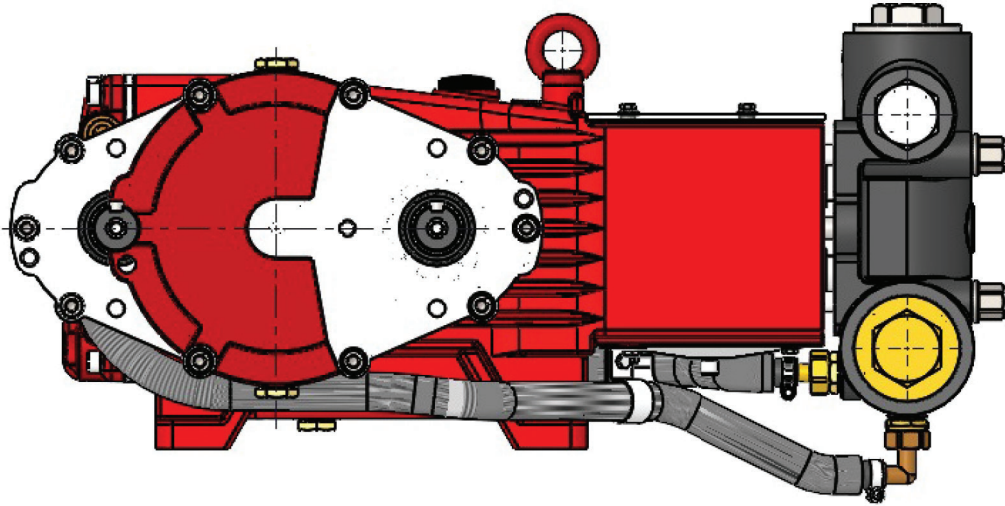

Coat O-ring (16) lightly with grease and place it into the groove of the casing bottom.

Fit the casing bottom with screws (84).

Tap the fitting pins (78) into both bores.

Press the pinion shaft (72 with bearing 74) into the bearing area of the casing bottom.

Put the spacer ring (80) onto the pump shaft.

Mount the fitting key (23) and then the gear wheel (72).

To ease fitting, the pinion can also be pushed away from the gear wheel due to the movability of the roller bearing (74).

Secure the gear wheel with the second spacer ring (81) and tension disc (82), coating screw (83) with Loctite before tightening. Coat seal (70) lightly on one side only.

Position the greased side onto the casing bottom.

Fit cylinder roller bearing (75) and shims (76) onto pinion (72B) and mount the casing top.

Making sure to carefully thread the pinion shaft through the radial shaft seal ring.

Where the UH version is concerned, fit adaptor flange (89) and centring ring (89A) using screws (87, 88).



Cover the sharp-edged fitting key groove with adhesive tape to avoid the radial shaft seal lip being damaged.

Use screws (85) to secure casing parts. Turn the drive several times by hand to check for smoothness.

To Dismantle Reduction Gear

Remove screws (85).

Press off casing top (69) by screwing two screws into both thread bores.

Push off casing top (69). Remove screw (83) and take off spacer ring (81) and tension disc (82).

Push the gear wheel off the crankcase by also screwing in two M10x110 screws towards the bearing cover side.

If required, supplementary assembly instructions can be requested from the manufacturer Giant Industries.