

Models

GP7545GB

GP7550GB

GP7555GB

Triplex Ceramic
Plunger Pump
Operating Instructions/
Repair and Service Manual

Gearbox Versions for Pinion Shaft Drives

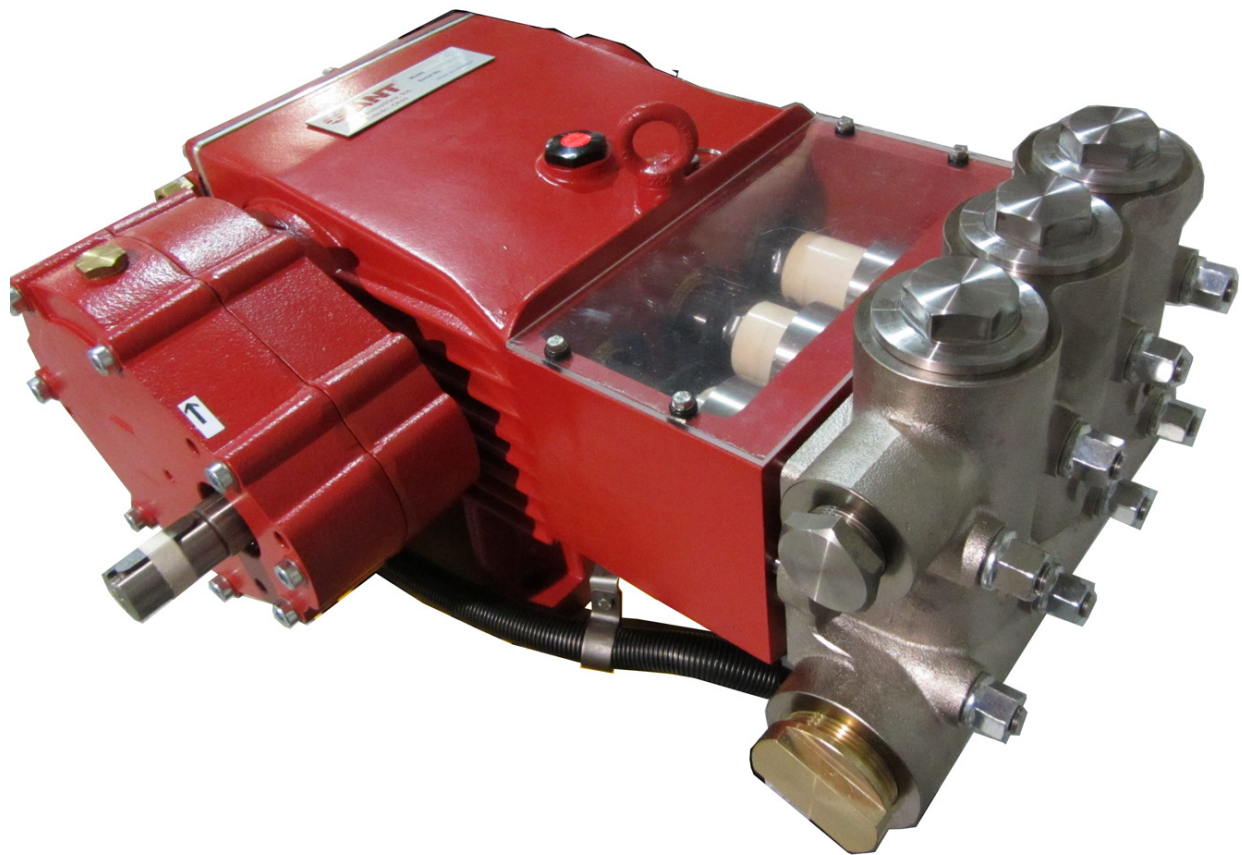

GIANT
Performance Under Pressure

Contents:

Installation Instructions:	page 2
Pump Specifications:	page 3
Dimensions:	page 3
Exploded View:	page 4
Parts List:	page 5
Kits:	page 6
Torque Specifications:	page 6
Maintenance Information:	page 6
Repair Instructions:	page 7
Warranty Information:	back page

Updated 02/25

INSTALLATION INSTRUCTIONS

Operation and Maintenance

Check oil level prior to starting and ensure trouble-free water supply.

Oil: Use only 1.6 gallons (6.0 liters) of SAE 80W-90 Industrial Gear Lube Oil (Giant's p/n 01154).

IMPORTANT! If the pump is mounted on a vehicle with the possibility of unlevelness and/or the pump speed is between 300 & 500 RPM, the volume of oil should be 2 gallons (7.5 liters). To check, put the oil dipstick in the bore situated next to the eye bolt.

Initial change after 50 hours and then after every 500 operating hours. If used less than this, change once per year.

IMPORTANT! When operating in humid areas (or areas with large temperature fluctuations, the oil must be changed immediately (if condensate or frothy oil occurs in the crankcase).

IMPORTANT! We recommend that both inlet ports be used in order to ensure cavitation-free operation and optimal suction conditions. If only one connection is used, a safety margin of 3 feet (1 meter) has to be added to the required NPSH.

IMPORTANT! The GP7545GB, GP7550GB and GP7555GB pumps have a black arrow on the reduction gear, which shows the preferred direction of rotation. The pump can be delivered either with the gear on the left side or right side (when facing the front of the pump), which eases planning assembled units with regard to the desired direction or rotation. **In either case, the larger gear wheel must rotate towards the front-end of the pump.**

The preferred/optimal direction of rotation ensures that the oil is correctly splashed on the crosshead guides via the motion of the connecting rods, which is a particular advantage where continuous operation is involved.

The pump can also be run against the recommended direction of the rotation if operated periodically or at reduced pressure. If this is the case, the pump has to be run in this direction to smoothen the bearing areas. This is done by a one-time operation at zero pressure for at least 30 minutes; thereafter, the pressure must be slowly increased over the next hour to the desired maximum operating pressure. This should run-in the pump, but you should also check the oil temperature, which should not exceed 160 ° F (71 °C).

The torque tension on the valve casing nuts (49A) is to be checked after approximately 200 hours. Please see page 6 for torque values.

IMPORTANT! The service life of the seals is maximized if a minimal amount of leakage is present. A few drops of water can drip from each plunger every minute. Leakage has to be examined every day. If the leakage becomes excessive (constant dripping), the plunger seals must be changed.

Safety Rules

The operating instructions must be read and adhered to before performing any work on the pump or complete assembled unit. No responsibility will be carried by us for damage to materials or persons caused by improper handling of our pumps.

Access to the pump is not allowed by unauthorized personnel. As safety valve is to be installed in accordance with the guidelines for liquid spraying units, so that the admissible

operating pressure cannot be exceeded by more than 10%. Pumps operating without a safety valve as well as any excess in temperature or speed limits automatically voids the warranty. When the pump is in operating, the exposed shaft side, the driven shaft side and its coupling must be covered by a protective guard. The plunger area must also be covered by the protective plate (30). Do not step onto the protective plate (30) or put weight on it.

Before carrying out any maintenance work to the pump or pump unit, the pressure in the discharge line and pump must be at zero. Close off the suction line. Disconnect fuses to ensure that the driving motor cannot accidentally get switched on. Before starting the pump, make sure that the pump, the cooling system and all parts on the pressure side of the unit are vented and refilled with pressure at zero.

In order to prevent air or air/water-mixture being absorbed and cavitation occurring, the pump NPSHR (Net Positive Suction Head Required) and water temperature must be adhered to.

Cavitation and/or compression of gases lead to uncontrollable pressure kicks, which can ruin the pump and unit parts and also be dangerous to the operator or anyone standing nearby.

Giant plunger pumps are only suitable for pumping fresh clean water.

Cooling the Gear Oil

IMPORTANT! The water input pressure must not exceed 29 PSI (2 bar) when using the integrated system for cooling the gear oil (standard version).

If a separate cooling circuit (maximum 29 PSI [2 bar]) is installed, it is then possible to have an input pressure of up to maximum 145 PSI (10 bar) on the suction side.

Make sure that suction pulsation is sufficiently dampened - water column resonance must be avoided.

IMPORTANT! The pumps can be run without gear oil cooling in continuous operation **up to** a power rating of **80 hp (60 kW)** or with major intermittent operation).

If operation power **exceeds 80 hp (60 kW)** or if continuous operation is the case, the pump must be run with the integrated oil cooling system. The maximum temperature of the water being pumped and which is also fed through the cooling system must not exceed 86 °F (30°C). The amount which is fed into the cooling system depends on the pump speed and is approximately 1.5 GPM (5.5 L/min) at 800 RPM. The cooling water is sucked in by one of the pumping chambers and pumped away.

IMPORTANT! The pump and cooling system must be emptied if there is a danger of frost. Note that travel wind can cause water in pumps fitted on open vehicles to freeze even if the outside temperature is above freezing point.

To empty the cooling circuit, remove the L-joints (K11) on the pump head (50). Blow out the circuit liquid (hoses K12) at the joint connection (K11/K7) using compressed air.

The torque tension on the valve casing nuts (49A) is to be checked after approximately 200 operating hours. Please refer to the section "Maintenance" concerning the torque values.

The pump must be at zero pressure when checking the torque tension.

NOTE: Contact Giant Industries for Service School Information. Phone: (419)-531-4600.

GP7500GB SERIES PUMP SPECIFICATIONS

U.S. Specifications

	Max. Flow	Max. Pressure	Max. Speed	Power Req'd.	Max. Temp.	Plunger Diameter
Model	GPM	PSI	RPM	HP	°F	in
GP7545GB	55.5	3000	900	111	86	1.77
GP7550GB	70	2540	900	121	86	1.97
GP7555GB	84.5	2000	900	118	86	2.17

Metric Specifications

	Max. Flow	Max. Pressure	Max. Speed	Power Req'd.	Max. Temp.	Plunger Diameter
Model	L/min	Bar	RPM	kW	°C	mm
GP7545GB	210	200	900	82.5	30	45
GP7550GB	265	175	900	90.0	30	50
GP7555GB	320	140	900	88.0	30	55

Horsepower Ratings:

We recommend a 1.15 service factor be specified when selecting an electric motor as the power source.

To compute electric motor horsepower required, use the following formula: $HP = (GPM \times PSI) / 1450$.

The formula to determine the horsepower required for a gas engine is: $HP = (GPM \times PSI) / 1150$.

The formula to determine the horsepower required for a diesel engine is: $HP = (GPM \times PSI) / 1250$.

For the Application of a Hydraulic Motor:

To Determine the Torque of a Hydraulic Motor -- $(GPM \times PSI \times 36.77) / RPM = \text{Torque (in-lbs)}$

Calculating RPM / GPM of Pump:

A pump must be connected to an electric motor or gas or diesel engine with the correct ratio of pulleys and belts to attain the required speed and GPM. The use of a Variable Frequency Drive (VFD) may also be used to control the RPM of a properly sized electric motor when variable flows are required.

$$(\text{Max. Pump RPM} / \text{Rated Pump GPM}) \times \text{Required Pump GPM} = \text{Required Pump RPM}$$

To calculate a pulley diameter one (1) pulley diameter and the required pump RPM must be known:

$$(\text{Pump RPM} \times \text{Pump Pulley Diameter}) / \text{Motor RPM} = \text{Motor Pulley Diameter}$$

$$(\text{Motor RPM} \times \text{Motor Pulley Diameter}) / \text{Pump RPM} = \text{Pump Pulley Diameter}$$

Common Specifications:

Inlet Pressure (w/out cooling system).....	-4.35 to 145 PSI (-0.3 to 10 Bar)
Inlet Pressure (w/cooling system).....	-4.35 to 29 PSI (-0.3 to 2 Bar)
Pinion Shaft Diameter.....	1.38" (35mm)
Crankcase Oil Capacity.....	2.1 Gal. (8.0 L)
Inlet Ports.....	(2) 2-1/2" NPT
Discharge Ports.....	(2) 1-1/4" NPT
Stroke.....	2.05" (52 mm)
Weight.....	469 lbs (213 kg)
Shaft Rotation.....	Pinion Shaft Towards Back of Pump

Materials Used for GP Pumps:

Manifold.....	Nickel-Plated Spheroidal Cast Iron
Plungers.....	Solid Ceramic Oxide
Valves.....	Stainless Steel
Seals.....	Nitrile with Fabric Reinforcing
Gear End.....	Spheroidal Cast Iron

GP7545GB, GP7550GB & GP7555GB Gear Ratios and Input Speeds

Gear Ratio	Input Speed
1.87:1	1683
2.25:1	2025
2.44:1	2196
2.73:1	2457

Exploded View - GP7545GB, GP7550GB & GP7555GB

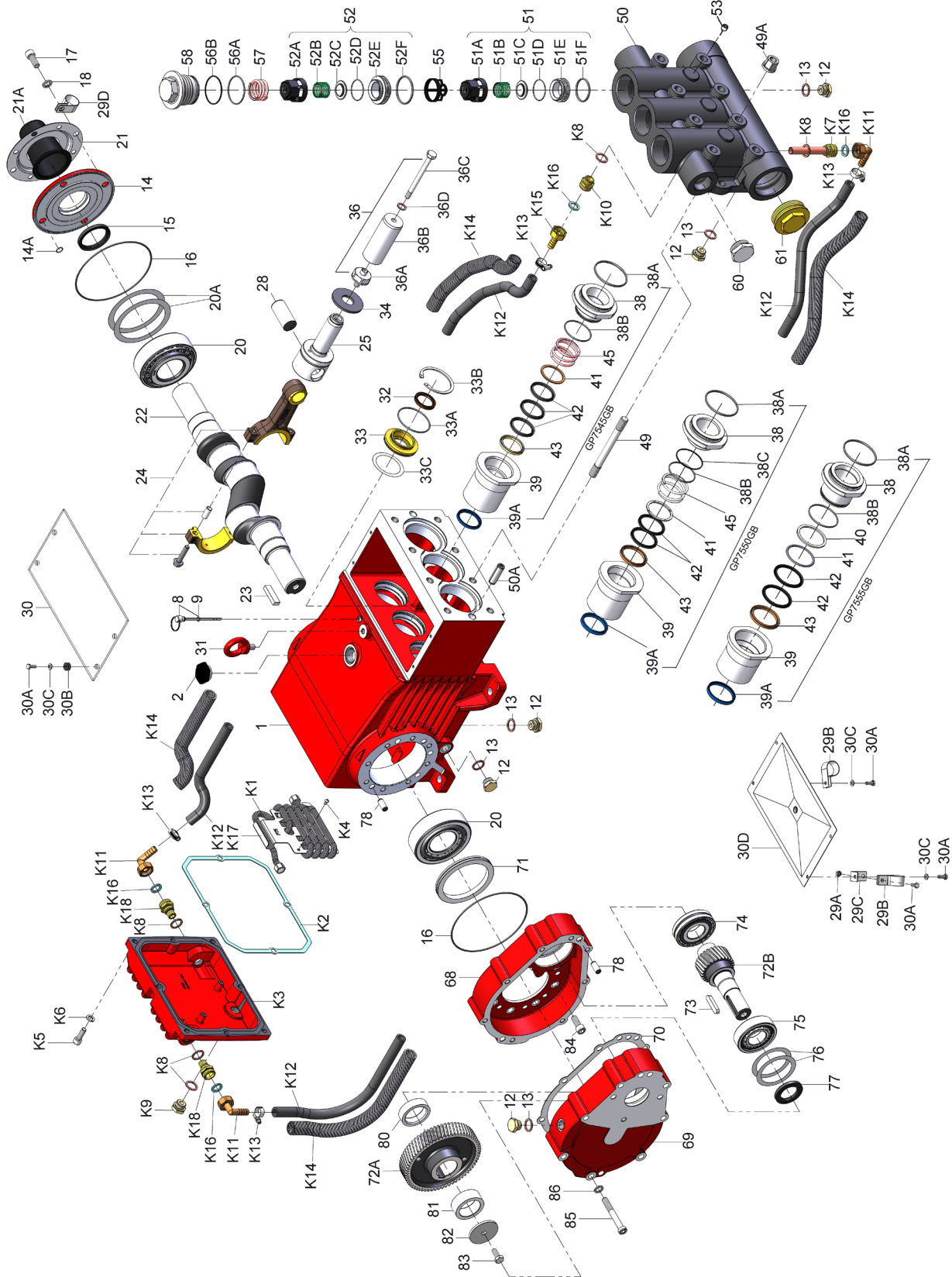

GP7545GB, GP7550GB & GP7555GB Spare Parts List

ITEM	PART	DESCRIPTION	QTY.	ITEM	PART	DESCRIPTION	QTY.
1	05769	Crankcase	1	45	13297	Tension Spring, GP7545GB	3
2	13000	Oil Filler Plug Assembly	1	45	07636	Pressure Spring, GP7550GB	3
8	07603	Oil Dip Stick	1	49	13159	Stud Bolt	8
9	01009	O-Ring, Dip Stick	1	49A	13160	Hexagon Nut	8
12	07109	Drain Plug	9	50	07791	Valve Casing	1
13	06272	Copper Seal for 12	9	50A	13162	Centering Stud	2
14	05770	Bearing Cover	1	51	05594	Inlet Valve Assembly (51A-51F)	3
14A	12204	O-Ring	4	51A	05595	Spring Tension Cap	3
15	05771	Radial Shaft Seal	1	51B	05450	Valve Spring	3
16	05772	O-Ring	2	51C	05247	Valve Plate	3
17	05642	Inner Hexagon Screw	4	51D	05596	O-Ring	3
18	05039	Spring Ring	4	51E	05597	Inlet Valve Seat	3
20	05773	Taper Roller Bearing	2	51F	05166	O-Ring	3
20A	05774	Fitting Disc (Shim)	1-5	52	05600	Discharge Valve Assembly	3
21	05645	Shaft Guard Holder	1	52A	05595	Spring Tension Cap	3
21A	05646	Shaft Guard	1	52B	05450	Valve Spring	3
22	04517	Crankshaft	1	52C	05247	Valve Plate	3
23	05776	Key	1	52D	05596	O-Ring	3
24	05777	Connecting Rod Assembly	3	52E	05598	Discharge Valve Seat	3
25	05778	Crosshead Assembly	3	52F	05599	O-Ring	3
28	05779	Crosshead Pin	3	53	22610	Plug, 1/4" NPT	3
29A	07408	Hexagon Nut	1	55	05647	Valve Spacer	3
29B	05383	Bracket 2 f. Cooling Hose	2	56A	07658	O-Ring	3
29C	05662	Fixing Bracket	1	56B	07635	Support Ring	3
29D	05381	Bracket 2 f. Cooling Hose	1	57	13173	Tension Spring	3
30	07619	Cover Plate	1	58	06682	Plug, M64 x 2	3
30A	07225-0100	Hexagon Screw	9	60	12251	Plug, 1-1/4" NPT	1
30B	13136	Grommet	4	61	05170	Plug, 2-1/2" NPT	1
30C	05053	Disc	8	68	05782	Bottom Casing for Gear	1
30D	13154	Cover	1	69	05783	Top Casing for Gear	1
31	07623	Eye Bolt	1	70	05784	Gear Seal	1
32	07624	Radial Shaft Seal	3	71	05785	Centering Ring	1
33	07626	Seal Retainer	3	72A/B	04531	Gear Wheel Set, i=1.87	1
33A	07627	O-Ring for Seal Retainer	3	72A/B	04519	Gear Wheel Set, i=2.25	1
33B	07628	Circlip for 33	3	72A/B	04156	Gear Wheel Set, i=2.44	1
33C	07249	Fitting Disc	3	72A/B	04518	Gear Wheel Set, i=2.73	1
34	13137	Oil Scraper (Flinger)	3	73	13243	Fitting Key	1
36	06165A	Plunger Assy. (36A-36D), GP7545GB	3	74	05787	Self-Aligning Roller Bearing	1
36	07630	Plunger Assy. (36A-36D), GP7550GB	3	75	05700	Cylinder Roller Bearing	1
36	07706	Plunger Assy. (36A-36D), GP7555GB	3	76	07117	Fitting Disc	1-5
36A	07667	Plunger Connection	3	77	05701	Radial Shaft Ring	1
36B	05157A	Plunger Pipe, GP7545GB	3	78	05665	Cylindrical Pin	4
36B	07793	Plunger Pipe, GP7550GB	3	80	05790	Spacer Ring 1 for Gear	1
36B	07666	Plunger Pipe, GP7555GB	3	81	05791	Spacer Ring 2 for Gear	1
36C	07664	Tensioning Screw	3	82	05802	Fixing Plate for Gear	1
36D	07665	Copper Ring	3	83	13358	Hexagon Screw	1
38	06167	Seal Case, GP7545GB	3	84	05792	Hexagon Socket Screw	7
38	07794	Seal Case, GP7550GB	3	85	05702	Hexagon Socket Screw	8
38	13155	Seal Case, GP7555GB	3	86	07159	Washer	8
38A	13156	O-Ring	3	90	03704	Oil Cooler Assembly	1
38B	06258	O-Ring, GP7545GB & GP7550GB	3	K1	03705	Stainless Steel Tubing	1
38B	07721	O-Ring, GP7555GB	3	K2	03708	Gear Cover Seal	1
38C	07635	Support Ring, GP7550GB	3	K3	03709	Gear Cover	1
39	06171	Seal Sleeve, GP7545GB	3	K4	03710	Clamping Screw	2
39	07795	Seal Sleeve, GP7550GB	3	K5	22706	Hexagon Socket Screw	8
39	13157	Seal Sleeve, GP7555GB	3	K6	06725	Washer	8
39A	13290	Grooved Ring, GP7545GB	3	K7	05755	Connection for Oil Cooler	1
39A	07796	Grooved Ring, GP7550GB	3	K8	06272	Copper Seal	5
39A	07723	Grooved Ring, GP7555GB	3	K9	07109	Plug, 1/2" BSP	1
40	07797	Support Ring, GP7555GB	3	K10	05031	Reducing Nipple	1
41	13296	O-Ring, GP7545GB	3	K11	05032	U-Joint Connector with Nut	3
41	05318	Support Ring, GP7550GB	3	K12	05033	Tube for Cooler	1.4 m
41	13158	O-Ring, GP7555GB	3	K13	05402	Hose Clamp	4
42	13294	V-Sleeve, GP7545GB	9	K14	05403	Hose Guard	1.3 m
42	07638	V-Sleeve, GP7550GB	6	K15	05404	Hose Coupling Nut	1
42	07711	V-Sleeve, GP7555GB	6	K16	05405	Flat Gasket	4
43	13293	Pressure Ring, GP7545GB	3	K17	03706	Hose Plate	1
43	07639	Pressure Ring, GP7550GB	3	K18	03707	Reduction Nipple	2
43	07712	Pressure Ring, GP7555GB	3		07662	Valve Tool (not shown)	1

Repair Kits - GP7545GB, GP7550GB & GP7555GB

Plunger Packing Kit, GP75545GB- # 09603

Item	Part #	Description	Qty.
38A	13156	O-Ring	3
38B	07721	O-Ring	3
39A	07723	Grooved Ring	3
42	07711	V-Sleeve	9

Inlet Valve Kit - # 09559

Item	Part #	Description	Qty.
51	05594	Inlet Valve Assembly	1
56A	07658	O-Ring	1
56B	07635	Support Ring	1

Plunger Packing Kit, GP7550GB- # 09526

Item	Part #	Description	Qty.
38A	13156	O-Ring	3
38B	06258	O-Ring	3
38C	07635	Support Ring	3
39A	07796	Grooved Ring	3
41	05318	Support Ring	3
42	07638	V-Sleeve	6

Large Discharge Valve Kit - # 09560

Item	Part #	Description	Qty.
52	05600	Discharge Valve Assy	1
55	05647	Valve Spacer	1
56A	07658	O-Ring	1
56B	07635	Support Ring	1

Plunger Packing Kit, GP7555GB- # 09220

Item	Part #	Description	Qty.
38A	13156	O-Ring	3
38B	07721	O-Ring	3
39A	07723	Grooved Ring	3
41	13158	Support Ring	3
42	07711	V-Sleeve	6

Small Discharge Valve Kit* - # 09561

Item	Part #	Description	Qty.
51B	05450	Valve Spring	1
51C	05247	Valve Plate	1
51D	05596	O-Ring	1
52F	05599	O-Ring	1
56A	07658	O-Ring	1
56B	07635	Support Ring	1

* The discharge valve seat (item 52E) can be flipped over and used. If it is damaged on both sides, order kit # 09660.

Oil Seal Kit - # 09221

Item	Part #	Description	Qty.
32	07624	Radial Shaft Seal	3
33A	07627	O-Ring	3

GP7545GB, GP7550GB & GP7555GB Torque Specifications

Position	Lubrication Info	Torque Specifications
1	Molycote Cu-Paste	
17		33 ft.-lbs. (45 Nm)
24		29.5 ft.-lbs. (40 Nm)
30A		88.5 in.-lbs. (10 Nm)
32	Loctite 403	
36A		33 ft.-lbs. (45 Nm)
36C	Loctite 243	29.5 ft.-lbs. (40 Nm)
49	Loctite 243	
49A		59 ft.-lbs. (80 Nm)
51E	Hylomar	
52E	Hylomar	
58		107 ft.-lbs. (145 Nm)
85		62.7 ft.-lbs. (85 Nm)
K2	Loctite 5910	
K5		33 ft.-lbs. (45 Nm)
K9		59 ft.-lbs. (80 Nm)
K18		124 in.-lbs. (14 Nm)

GP7545GB, GP7550GB & GP7555GB Repair Instructions

TO CHECK VALVES

Loosen plugs (58), take out tension spring (57) and then remove the complete valve assembly (#51 & 52) with either a valve tool or an M16 hexagon screw. Check sealing surfaces and replace worn parts. The discharge valve seat (# 52E) can be used on both sides. If you re-use it, make sure you switch the O-Ring (#51D) to the opposite side. Check O-rings and support rings. Tighten plugs (58) to 107 ft.-lbs. (145 NM).

TO CHECK SEALS AND PLUNGER PIPE

Loosen nuts (49A) and remove pump head (50). Separate the plunger connection (36A) from the crosshead (25) by means of an open-end wrench (size 36mm). Pull seal sleeves (39) out of their fittings in the crankcase (1). Take the seal case (38) out of the seal sleeve (39). Examine the plunger parts (36A-36D), seals (42 & 39A) and O-rings (38A & 38B). When replacing the plunger pipe (36B), tighten tension screws (36C) to 30 ft. lbs. (40 NM). Replace worn parts; grease seals with Silicone before installing.

CAUTION: Don't loosen the (3) plunger connections (36A) before the valve casing has been removed otherwise the tension screw (36C) could hit against the valve adapter (56) when the pump is being turned. Seal life can be increased if the pre-tensioning allows for a little leakage. This assists lubrication and keeps the seals cool. It is therefore not necessary to replace seals before the leakage becomes too heavy and causes output and operating pressure to drop.

MOUNTING VALVE CASING

Check O-rings (38A & 38B) on the seal case (38). Clean surfaces of seal sleeves in gear box and sealing surfaces of valve casing (50). Push the valve casing carefully on the O-rings of the seal case and centering studs (50A). Tighten nuts (49A) to 103 ft. lbs. (140 NM).

TO DISASSEMBLE GEAR

Take out plunger (36) and seal sleeves (39) as described above. Drain the oil. After removing the circlip ring (33B), lever out seal retainer (33) with a screw driver. Check seals (32 & 33A) and surfaces of crosshead (25).

Important! Seal (32) must always be installed so that the seal-lip on the inside diameter faces the oil. Possible axial float of the seal retainer (33) should be compensated with the shims (33C).
Remove the crankcase cover (4). Loosen inner hexagon screws on the connecting rods (24).

Note: Connecting rods are marked for identification. Do not twist connecting rod halves. Each connecting rod is to be reinstalled in the same position (and orientation) on the crankshaft journals.
Push the connecting rod halves as far into the crosshead guide as possible. Take out the bearing cover (14).

TO DISMANTLE REDUCTION GEAR

Remove screws (G4). Remove the gear cover (G2). It may be necessary to tap the cover off with a rubber mallet. Remove screw (G11) and take off the spacer ring (G7) and tension disc (G10). Push the cogwheel (G9) off the shaft by screwing two screws into both thread bores. Unscrew hexagon screws (10) and remove the shaft cover (21) and bearing cover (14). Finally, take the crankshaft (22) out of the crankcase by tapping it towards the bearing cover side, opposite the gearbox, using a rubber hammer.

Check the surfaces of connecting rods (24), crankshaft (22) and crossheads (25). Check the surfaces of the crosshead guides in the crankcase for any unevenness.

Reassemble in reverse order. Regulate axial bearing clearance to a minimum of 0.1mm and a maximum 0.15mm by means of fitting discs (20A). Insert the crankshaft by passing it through on the bearing cover side. Press in the outer bearing ring (20). The crankshaft should turn easily and with little clearance. Fit the bearing cover (14) and tighten screws (24) to 30 ft.-lbs. (40 Nm).

Important! The connecting rod has to be able to slightly move sidewise at the crankshaft journal.

Heat the ball bearings (G13) before pressing them onto the pinion (G12). Slightly press the cogwheel (G9) onto the crankshaft, so that the pinion (G12) together with the bearing (G13) can still be inserted.

When mounting, place the pinion (G12) onto the cogwheel so that they correctly interlock. Carefully tap the cogwheel and the pinion simultaneously onto the crankshaft and into the bearing seat.

Fit tension disc (G10), and spacer ring (G7) and tighten screw (G11) with Loctite.

Fit seal (G14) on to the cylindrical pins (G3).

Push the gear cover (G2) carefully on to the bearing (G13). Make sure the radial shaft seal (G17) does not get damaged during fitting on to the pinion.

Important! Before putting into operation again, turn the reduction gear shaft by hand at least four full turns to make sure that the gear is correctly aligned.

GP7545GB, GP7550GB & GP7555GB Dimensions - Inches (mm)

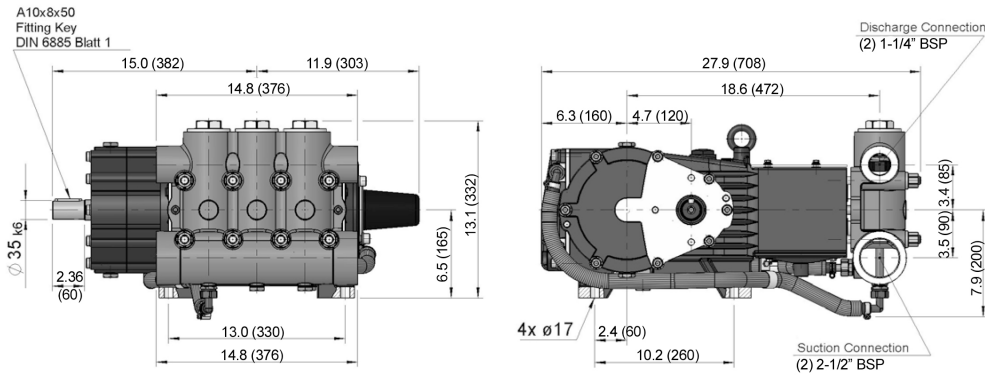

GIANT INDUSTRIES LIMITED WARRANTY

Giant Industries, Inc. pumps and accessories are warranted by the manufacturer to be free from defects in workmanship and material as follows:

1. Five (5) years from the date of shipment for all pumps used in portable pressure washers with NON-SALINE, clean water applications.
2. Two (2) years from the date of shipment for Giant pumps used in car wash applications.
3. One (1) year from the date of shipment for all other Giant industrial and consumer pumps.
4. Six (6) months from the date of shipment for all rebuilt pumps
5. Ninety (90) days from the date of shipment for all Giant accessories.

This warranty is limited to repair or replacement of pumps and accessories of which the manufacturer's evaluation shows were defective at the time of shipment by the manufacturer. The following items are NOT covered or will void the warranty:

1. Defects caused by negligence or fault of the buyer or third party.
2. Normal wear and tear to standard wear parts.
3. Use of repair parts other than those manufactured or authorized by Giant.
4. Improper use of the product as a component part.
5. Changes or modifications made by the customer or third party.
6. The operation of pumps and or accessories exceeding the specifications set forth in the Operations Manuals provided by Giant Industries, Inc.

Liability under this warranty is on all non-wear parts and limited to the replacement or repair of those products returned freight prepaid to Giant Industries which are deemed to be defective due to workmanship or failure of material. A Returned Goods Authorization (R.G.A.) number and completed warranty evaluation form is required prior to the return to Giant Industries of all products under warranty consideration. Call (419)-531-4600 or fax (419)-531-6836 to obtain an R.G.A. number.

Repair or replacement of defective products as provided is the sole and exclusive remedy provided hereunder and the MANUFACTURER SHALL NOT BE LIABLE FOR FURTHER LOSS, DAMAGES, OR EXPENSES, INCLUDING INCIDENTAL AND CONSEQUENTIAL DAMAGES DIRECTLY OR INDIRECTLY ARISING FROM THE SALE OR USE OF THIS PRODUCT.

THE LIMITED WARRANTY SET FORTH HEREIN IS IN LIEU OF ALL OTHER WARRANTIES OR REPRESENTATION, EXPRESS OR IMPLIED, INCLUDING WITHOUT LIMITATION ANY WARRANTIES OR MERCHANTABILITY OR FITNESS FOR A PARTICULAR PURPOSE AND ALL SUCH WARRANTIES ARE HEREBY DISCLAIMED AND EXCLUDED BY THE MANUFACTURER.



WARNING: This product might contain a chemical known to the State of California to cause cancer, and birth defects or other reproductive harm.
For more information go to www.P65Warnings.ca.gov

GIANT
Performance Under Pressure

GIANT INDUSTRIES, INC., 900 N. Westwood Ave., Toledo, Ohio 43607
PHONE (419) 531-4600, FAX (419) 531-6836, www.giantpumps.com
© Copyright 2025 Giant Industries, Inc.