

P400 Series - 18mm Versions

Triplex Ceramic
Plunger Pump
Operating Instructions/
Repair and Service Manual

For Models:

P435

P450

P451

P455B

P456B

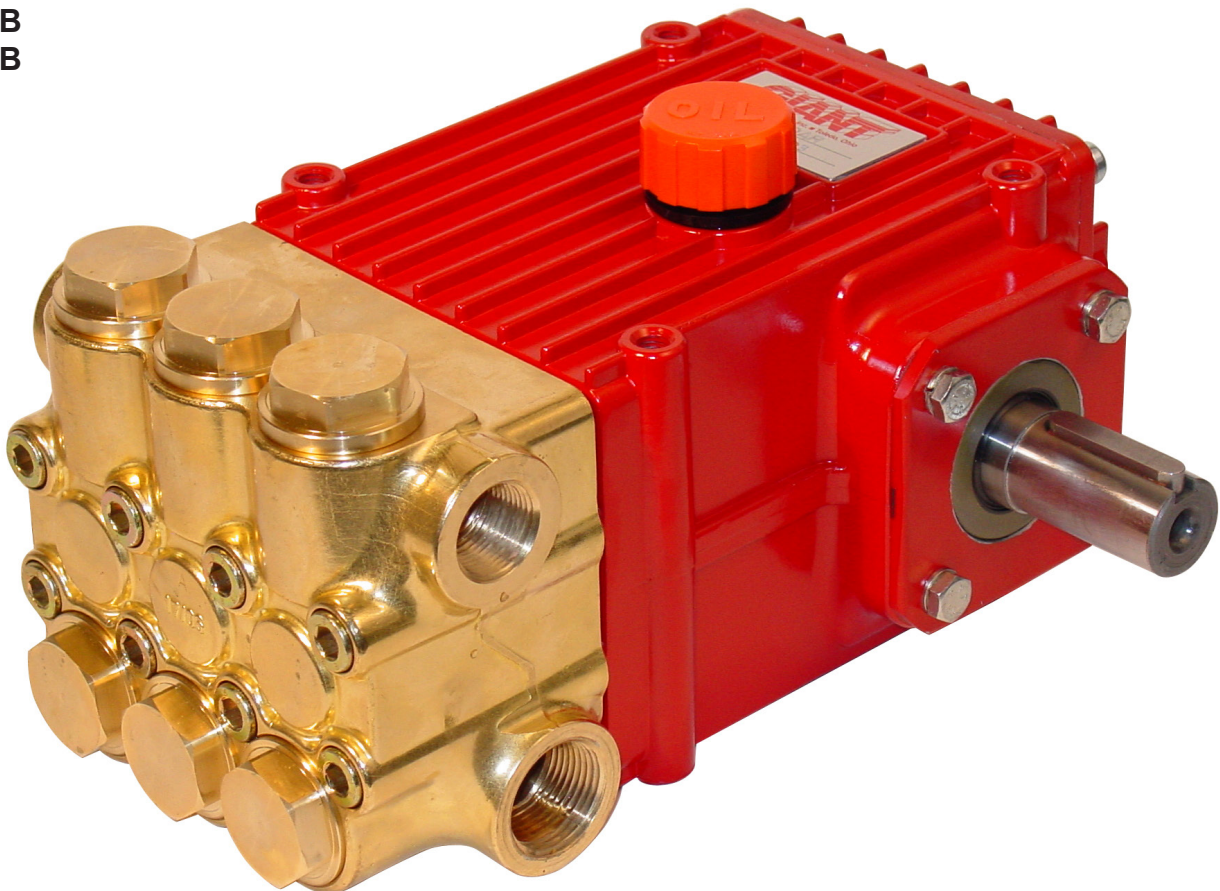

Brass Version Shown

GIANT
Performance Under Pressure

Updated 06/22

Contents:

Installation Instructions:

Pump Specifications:

Exploded View:

Parts List/Kits:

Torque Specifications:

Repair Instructions:

Dimensions:

Warranty Information

page 2

pages 3

page 4

page 5

page 5

pages 6-7

back page

back page

INSTALLATION INSTRUCTIONS

Required NPSH refers to water (specific weight 1kg/dm³) at maximum permissible pump revolutions.

Operation and Maintenance

Check oil level prior to starting to ensure trouble-free water supply.

Important! If there is a **danger of frost**, the water in the pump and in the pump fittings (particularly the unloader valve) must be emptied. The second discharge port can also be used and the pump run "dry" for 1-2 minutes for this purpose.

Oil amount: 30.4 ounces (0.9 liters). Only use **ISO VG 220 industrial gear oil** (e.g. Aral Degol BG220) or **automobile gear oil SAE 90 GL4** (Giant p/n 01154).

Initial oil change after 50 operating hours and then every 500 hours, after 1 year if used less. Caution when operating in damp places or with high temperature fluctuations. Oil must be changed immediately should condensate (frothy oil) occur in the gear box.

NPSH values must be observed.

Maximum input pressure 145 PSI (10 bar), maximum suction head -4.35 PSI (-0.3 bar). Make sure that suction pulsation is sufficiently dampened - water column resonance must be avoided.

Important! If the pump is not used for a long period of time, it is possible the seals (23) could become hard or brittle thus causing the pump to leak when put into operation.

If this is the case, we recommend these seals be replaced every 4 years.

Safety Rules

A safety valve is to be installed in accordance with the guidelines for liquid spraying units so that the admissible operating pressure cannot be exceeded by more than 10%. Pump operation without a safety valve as well as any excess in temperature or speed limits automatically voids the warranty.

When the pump is in operation, the drive shaft end and the coupling must be enclosed by a protective cover or a coupling bell.

Pressure in the discharge line and pump must be at zero before any maintenance to the pump takes place. Shut off suction line. Disconnect fuses to ensure that the driving motor does not get switched on accidentally. Make sure that all parts on the pressure side of the unit are vented before starting the pump. In order to prevent air, or an air-water mixture being absorbed and to prevent cavitation occurring, the pump NPSHR (=suction head) and water temperature must be respected.

Cavitation and/or compression of gases lead to uncontrollable pressure kicks which can ruin pump and unit parts and also be dangerous to the operator or anyone standing nearby.

Giant Plunger Pumps are suitable for pumping clean water and other non-aggressive or non-abrasive media with a specific weight similar to water.

Before pumping other liquids - especially inflammable, explosive and toxic media - the pump manufacturer must be consulted with regard to the resistance of the pump material. It is the responsibility of the equipment manufacturer and/or operator to ensure that all pertinent safety regulations are adhered to.

PUMP SPECIFICATIONS - P400 - 18MM PUMPS

U.S. Measurements

	Max. Flow	Max. Pressure	Max. Speed	Power Required	Max. Temp	Plunger Diameter	Stroke	Weight
Model	GPM	PSI	RPM	HP	F	in	in	lbs
P450	5.5	5100	1450	19.8	160	0.71	0.79	38.3
P455B	5.5	4350/5100 ⁺	1450	16.5/19.2 ⁺	160	0.71	0.79	38.3
P451	5.8	5100	1725	20.4	160	0.71	0.72	38.3
P456B	5.8	4350/5100 ⁺	1725	17.4/20.3 ⁺	160	0.71	0.72	38.3
P435	6.6	3625	1450	16.5	160	0.71	0.94	38.3

Metric Measurements

	Max. Flow	Max. Pressure	Max. Speed	Power Required	Max. Temp	Plunger Diameter	Stroke	Weight
Model	L/min	Bar	RPM	kW	C	mm	mm	kg
P450	20.8	350	1450	14.8	70	18	20	17.4
P455B	20.8	300/350 ⁺	1450	12.3/14.3 ⁺	70	18	20	17.4
P451	22.0	350	1725	15.2	70	18	18.2	17.4
P456B	22.0	300/350 ⁺	1725	13.0/15.1 ⁺	70	18	18.2	17.4
P435	25.0	250	1450	12.3	70	18	24	17.4

⁺Continuous/Intermittent Duty

Consult the factory for special requirements that must be met if the pump is to operate beyond one or more of the limits specified above.

Horsepower Ratings:

We recommend a 1.15 service factor be specified when selecting an electric motor as the power source.

To compute electric motor horsepower required, use the following formula: $HP = (GPM \times PSI) / 1450$.

The formula to determine the horsepower required for a gas engine is: $HP = (GPM \times PSI) / 1150$.

The formula to determine the horsepower required for a diesel engine is: $HP = (GPM \times PSI) / 1250$.

For the Application of a Hydraulic Motor:

To Determine the Torque of a Hydraulic Motor -- $(GPM \times PSI \times 36.77) / RPM = \text{Torque (in-lbs)}$

Calculating RPM / GPM of Pump:

A pump must be connected to an electric motor or gas or diesel engine with the correct ratio of pulleys and belts to attain the required speed and GPM. The use of a Variable Frequency Drive (VFD) may also be used to control the RPM of a properly sized electric motor when variable flows are required.

$$(\text{Max. Pump RPM} / \text{Rated Pump GPM}) \times \text{Required Pump GPM} = \text{Required Pump RPM}$$

To calculate a pulley diameter one (1) pulley diameter and the required pump RPM must be known:

$$(\text{Pump RPM} \times \text{Pump Pulley Diameter}) / \text{Motor RPM} = \text{Motor Pulley Diameter}$$

$$(\text{Motor RPM} \times \text{Motor Pulley Diameter}) / \text{Pump RPM} = \text{Pump Pulley Diameter}$$

Common Specifications:

Inlet Pressure145 PSI (10 Bar)
 Crankshaft Diameter.....1.1" (28mm)
 Keyway Width.....8mm
 Crankcase Oil Capacity30.4 fl. oz. (0.9 L)
 Inlet Ports(2) 3/4" or (2) 1/2" BSP*
 Discharge Ports.....(2) 1/2" BSP
 Shaft Rotation.....Top of Pulley Toward Fluid End

Materials Used for P400 Pumps:

Manifold
 (P450/P451) ... Aluminum Bronze
 (others) Forged Brass
 Plungers Solid Ceramic Oxide
 Valves 316 Stainless Steel
 Seals..... Nitrile with Fabric Reinforcing
 Gear End Aluminum

*1/2" BSP for P450/P451/P456 and
 3/4" BSP for P435 and P455

EXPLODED VIEW - P435/P450/P451/P455B/P456

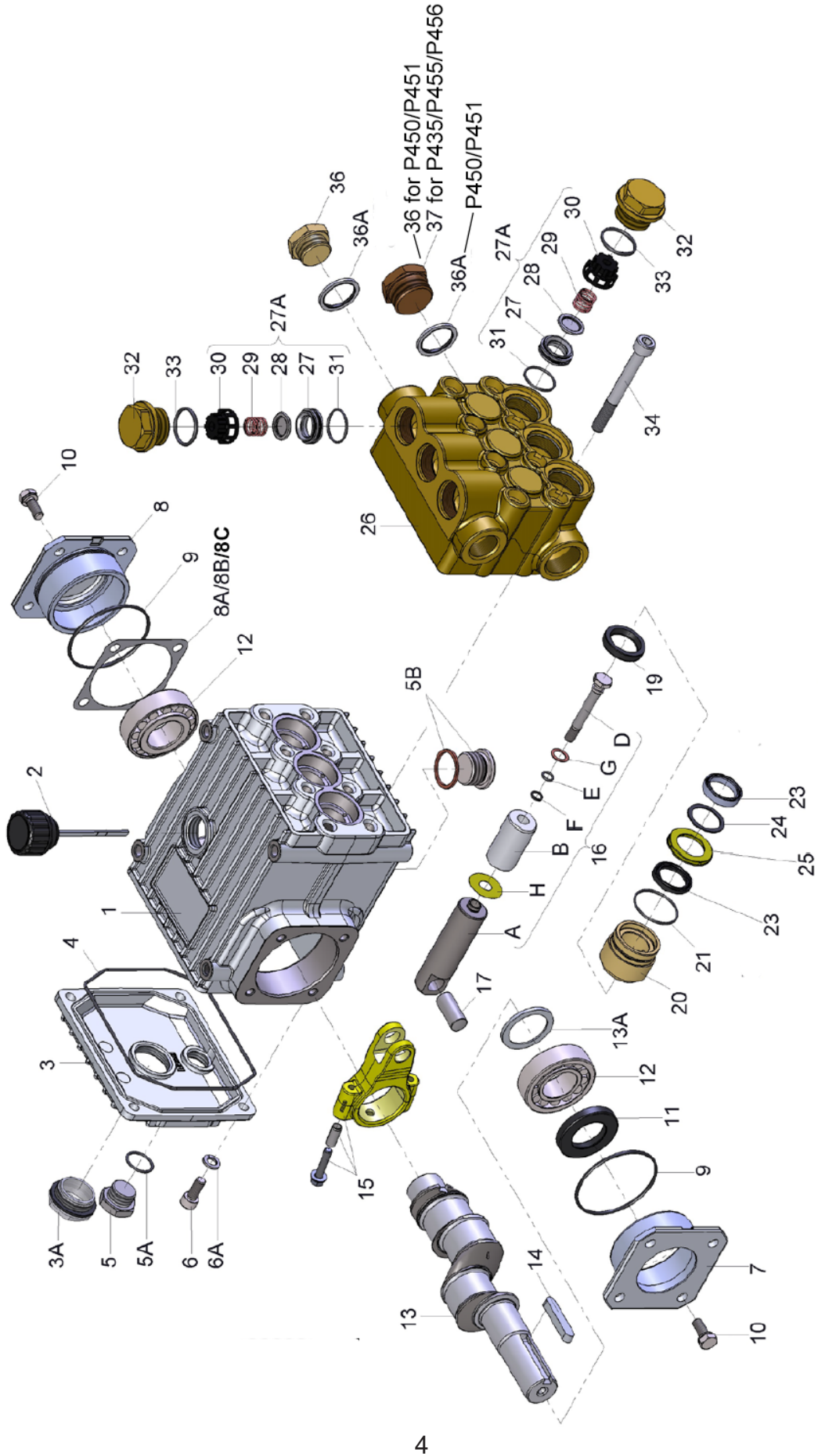

P435/P450/P451/P455B/P456 SPARE PARTS LIST

ITEM	PART	DESCRIPTION	QTY.	ITEM	PART	DESCRIPTION	QTY.
1	08377	Crankcase	1	16F	07203	Backup Ring	3
2	08378	Oil Fill Plug with Gasket	1	16G	07258	Copper Washer	3
3	06479	Crankcase cover	1	16H	06431	Oil Scraper	3
3A	07186	Oil Sight Glass w/ Gasket	1	17	06790	Crosshead Pin	3
4	08380	O-Ring	1	19	05444	Oil Seal	3
5	07109	Oil Drain Plug	1	20	05534	Seal Case	3
5A	06015	O-Ring for Oil Drain Plug	1	21	07266	O-Ring	3
5B	08092	Plug with Gasket	1	23	08477	V-Sleeve, 18mm	6
6	01010	Screw	4	24	07929	Pressure Ring	3
6A	01011-0400	Spring Washer	4	25	03476	Weep Return Ring	3
7	04739	Bearing Cover Open	1	26	05574	Manifold (P435/P455/P456)	1
8	05291	Bearing Cover Closed	1	26	08470	Manifold (P450/P451)	1
8A	05292	Shim	1-3	27A	05543	Valve Assembly (Items 27-31)	6
8B	05293	Shim (May not be present)	1	27	05541	Valve Seat	6
8C	05964	Shim	1-2	28	05542	Valve Plate	6
9	01016	O-Ring	2	29	07906	Valve Spring	6
10	07114	Screw with Washer	8	30	07907	Valve Spring Retainer	6
11	07459	Radial Shaft Seal	1	31	07770	O-Ring	6
12	05350	Taper Roller Bearing	2	32	05544	Plug (P435/P455/P456)	6
13	04741	Crankshaft (P435)	1	32	08406	Plug (P450/P451)	6
13	04740	Crankshaft (P450/P455B)	1	33	05545	O-Ring (P435/P455/P456)	6
13	03173	Crankshaft (P451/P456)	1	33	07489	O-Ring (P450/P451)	6
13A	04742	Spacer Ring	1	34	08484	Cap Screw (P435/P455/P456)	8
14	08091	Fitting Key	1	34	08396	Cap Screw (P450/P451)	8
15	08390	Connecting Rod Assembly	3	36	13434	Plug, 1/2" BSP (P435/P455/P456)	1
16	05484	Plunger Assy.(Items 16A-16H)	3	36	13434	Plug, 1/2" BSP (P450/P451)	2
16A	05352	Plunger Base	3	36A	06272	Copper Washer (P435/P455/P456)	1
16B	08397	Plunger Pipe	3	36A	06272	Copper Washer (P450/P451)	2
16D	08399	Tension Screw	3	37	07703	Plug, 3/4" BSP (P435/P455/P456)	1
16E	07023	O-Ring	3				

P435/P450/P451/P455B/P456 REPAIR KITS

Plunger Packing Kit - # 09141

Item	Part#	Description	Qty
21	07266	O-Ring	3
23	08477	V-Sleeve	6
24	07929	Pressure Ring	3

Oil Seal Kit - #09641

Item	Part #	Description	Qty
19	05444	Oil Seal	3

Valve Assembly Kits

P435/P455/P456 - # 09644

Item	Part #	Description	Qty
27A	05543	Valve Assembly, Complete	6
33	05545	O-Ring	6

P450/P451 - # 09770

Item	Part #	Description	Qty
27A	05543	Valve Assembly, Complete	6
33	07489	O-Ring	6

TORQUE & LUBRICATION SPECIFICATIONS - P435/P450/P451/P455B/P456

Position	Item #	Description	Lubrication Information	Torque Amount
3A	07186	Oil Sight Glass	Loctite 5910	106 in.-lbs. (12 Nm)
5	07109	Oil Drain Plug		59 ft.-lbs. (80 Nm)
5B	08092	Plug with Gasket		59 ft.-lbs. (80 Nm)
6	01010	Screw		110 in.-lbs. (12.5 Nm)
10	07114	Screw with Washer		132 in.-lbs. (15 Nm)
15	08390	Screw with Washer		97 in.-lbs. (11 Nm)
16D	08399	Tension Screw	Loctite 243	247 in.-lbs. (28 Nm)
32	05544/08406	Plug	Loctite 243	125 ft.-lbs. (170 Nm)
34	08396/08484	Cap Screw	Lightly Oil	30 ft.-lbs. (40 Nm)

REPAIR INSTRUCTIONS - P435/P450/P451/P455B/P456

Note: Always take time to lubricate all metal and nonmetal parts with a light film of oil before reassembly. This step will ensure proper fit, at the same time protecting the pump nonmetal parts (i.e., the elastomers) from cutting and scoring.

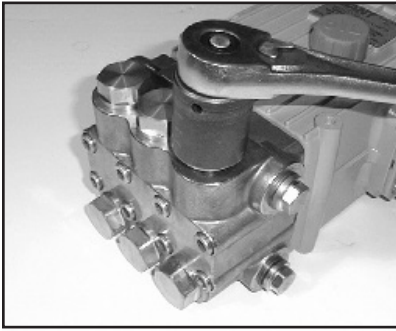

- 1) With a socket wrench, remove the three discharge valve plugs and three inlet valve plugs (32). Inspect the o-ring (33) for wear and replace if damaged.

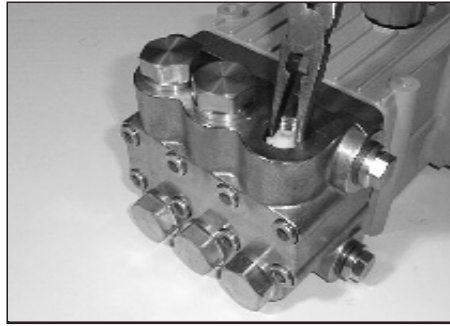

- 2) Using needle nose pliers, remove the inlet and discharge valve assemblies (27A). Note: It may become necessary to remove the valve seat (27) from the valve casing using a slidehammer.

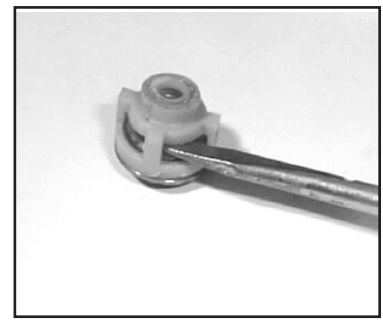

- 3) By inserting a small screwdriver between the valve seat (27) and the valve spring retainer (30), the valve assembly can be separated.



- 4) Remove the o-ring (31). Inspect all parts for wear and replace as necessary. Apply one drop of loctite 243 to the valve plugs (32) and tighten to 125 ft. lbs. (170 Nm).

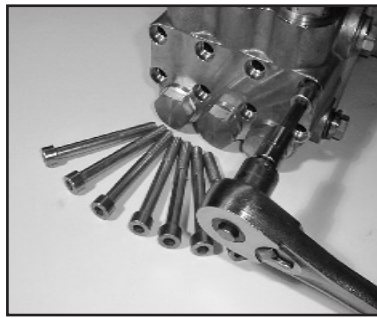

- 5) Use a 8mm allen wrench to remove the 8 socket head cap screws (34). Carefully slide the valve casing (26) out over the plungers.

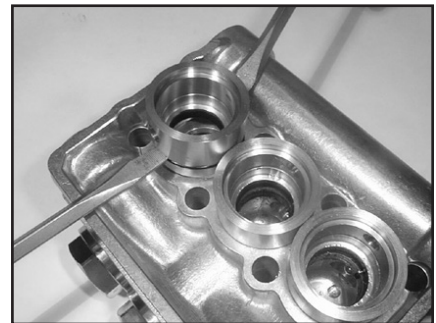

- 6) Remove seal adaptors (20) and weep return rings (25) from the valve casing.



- 7) Remove the pressure rings (24) and v-sleeves (23) from the valve casing (26).



- 8) Remove the weep grooved seal (23) out of the seal adaptor (20). Check O-rings (21).

IMPORTANT! The grooved seal (23) on the high-pressure side is to be fitted carefully into the valve casing (26) using a screwdriver. Under no circumstances must the seal surface in the valve casing or the seal lip be damaged.

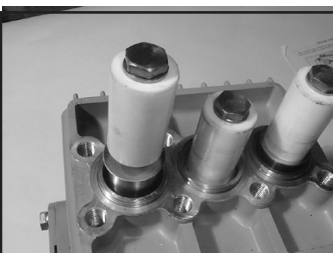

- 9) Check surfaces of plunger (16). Damaged surfaces cause accelerated seal wear. Deposits of all kinds must be removed from the plungers.

IMPORTANT! Plunger surfaces are not to be damaged. If there are lime deposits in the pump, care must be taken that the drip-return bore in parts (25) and (26) ensure trouble-free drip-return.

REPAIR INSTRUCTIONS - P435/P450/P451/P455B/P456

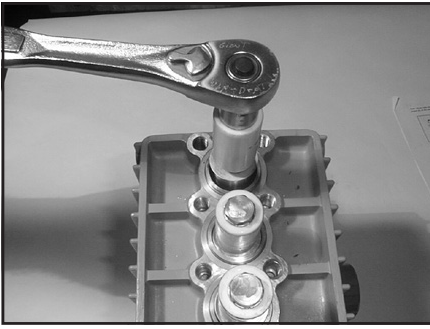

10) If the plunger pipe (16B) is worn, remove tension screw (16D) and remove along with plunger pipe (16B). Check and clean plunger surface (16A), check oil scraper (16H). Cover thread of tension screw (16D) with a thin film of Loctite and tighten carefully to 247 in.-lbs. (28 Nm).

IMPORTANT! Care must be taken that glue does not get between the plunger pipe (16B) and centring sleeve (16C). The plunger pipe should not be strained by eccentric tightening of the tension screw or through damage to front surface of plunger, otherwise it is liable to fracture.

11) After installation of high pressure seals (23), place seal adaptor (20) with weep seals & pressure ring installed, weep return ring (25) and high pressure weep return ring (24) over plungers. Slide valve casing over plungers and seat firmly. Replace the 8 socket head cap screws (34) and tighten to 30 ft.-lbs. (40 Nm) in a crossing pattern (as shown to the right).

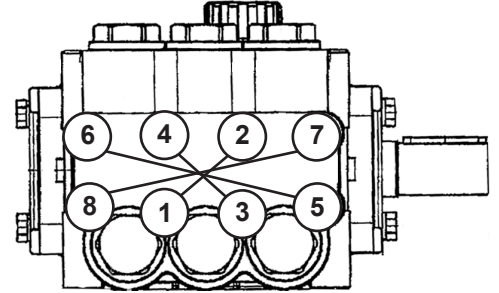

Gear End

If oil leaks where the plunger (16) extends from the crankcase (1), the oil seals (19) and plungers (16) must be examined and replaced if necessary. Remove oil plug (5) and drain oil; remove crankcase cover (3). Remove valve casing (26), and seal case (20). Then remove plunger pipes (16B) and oil scrapers (16H) as described above.

IMPORTANT! Before removing connecting rods be aware of their position on the crankshaft so as to return them to the same location and orientation when re-assembling.

Remove screws from connecting rods (15), separate the back connecting rod half from the crankshaft and the front connecting rod half. The connecting rod halves must be kept as pairs - do not mix them up. Push connecting rod shaft as far as possible into the crosshead guide. Remove screws (10) and pry bearing covers (7,8) off gently with a screwdriver.

Carefully remove crankshaft (13) by threading it through the connecting rods (15), making sure not to bend the connecting rods. Remove and disassemble connecting rods and plungers (16) paying close attention not to damage the plungers. Pry out oil seal (19) using a screwdriver. Examine plunger surfaces (16A) and replace if necessary.

To re-assemble, first press the oil seal (19) into the crankcase. Then insert connecting rods with plungers remembering their original location. Thread in the crankshaft (13). Replace bearing cover (7) and o-ring (9) together with the radial shaft seal (11) and roller bearing (12) and fix in place with screws (10). Replace roller bearing (12), bearing cover (8) and o-ring (9). Adjust the clearance by fitting shims (8A) under the bearing cover as required to ensure that the crankshaft (13) turns easily without play being felt. Finally, mount connecting rod halves on crankshaft matching them with other half and tighten screws (15) to 97 in-lb (11 Nm). Replace crankcase cover (3) and o-ring (4). When remounting the valve casing (26), tighten hexagon socket screws (34) to 30 ft.-lb (40 Nm).

To Move Crankshaft to Opposite Side

Remove the valve casing (26) and seal case (20). Then rotate the crankcase 180°. Interchange the oil plug ((5B) with oil dipstick (2). Rotate the crankcase cover (3) 180°. Remount the valve casing together with the seal casing and the seal adapters (20). **Make sure that the seal adapters are rotated in order that the bores face downwards.**

**Contact Giant Industries for service school information.
Phone: (419) 531-4600**

P435/P450/P451/P455B/P456 Dimensions - in (mm)

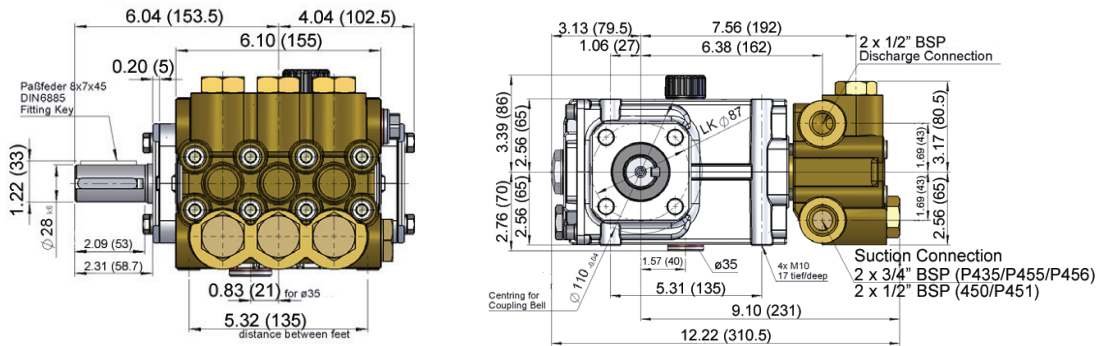

GIANT INDUSTRIES LIMITED WARRANTY

Giant Industries, Inc. pumps and accessories are warranted by the manufacturer to be free from defects in workmanship and material as follows:

1. Five (5) years from the date of shipment for all pumps used in portable pressure washers with NON-SALINE, clean water applications.
2. Two (2) years from the date of shipment for Giant pumps used in car wash applications.
3. One (1) year from the date of shipment for all other Giant industrial and consumer pumps.
4. Six (6) months from the date of shipment for all rebuilt pumps
5. Ninety (90) days from the date of shipment for all Giant accessories.

This warranty is limited to repair or replacement of pumps and accessories of which the manufacturer's evaluation shows were defective at the time of shipment by the manufacturer. The following items are NOT covered or will void the warranty:

1. Defects caused by negligence or fault of the buyer or third party.
2. Normal wear and tear to standard wear parts.
3. Use of repair parts other than those manufactured or authorized by Giant.
4. Improper use of the product as a component part.
5. Changes or modifications made by the customer or third party.
6. The operation of pumps and or accessories exceeding the specifications set forth in the Operations Manuals provided by Giant Industries, Inc.

Liability under this warranty is on all non-wear parts and limited to the replacement or repair of those products returned freight prepaid to Giant Industries which are deemed to be defective due to workmanship or failure of material. A Returned Goods Authorization (R.G.A.) number and completed warranty evaluation form is required prior to the return to Giant Industries of all products under warranty consideration. Call (419)-531-4600 or fax (419)-531-6836 to obtain an R.G.A. number.

Repair or replacement of defective products as provided is the sole and exclusive remedy provided hereunder and the MANUFACTURER SHALL NOT BE LIABLE FOR FURTHER LOSS, DAMAGES, OR EXPENSES, INCLUDING INCIDENTAL AND CONSEQUENTIAL DAMAGES DIRECTLY OR INDIRECTLY ARISING FROM THE SALE OR USE OF THIS PRODUCT.

THE LIMITED WARRANTY SET FORTH HEREIN IS IN LIEU OF ALL OTHER WARRANTIES OR REPRESENTATION, EXPRESS OR IMPLIED, INCLUDING WITHOUT LIMITATION ANY WARRANTIES OR MERCHANTABILITY OR FITNESS FOR A PARTICULAR PURPOSE AND ALL SUCH WARRANTIES ARE HEREBY DISCLAIMED AND EXCLUDED BY THE MANUFACTURER.



WARNING: This product might contain a chemical known to the State of California to cause cancer, and birth defects or other reproductive harm.
For more information go to www.P65Warnings.ca.gov

GIANT
Performance Under Pressure

GIANT INDUSTRIES, INC.
900 N. Westwood Ave., Toledo, Ohio 43607
PHONE (419) 531-4600 FAX (419) 531-6836
www.giantpumps.com
© Copyright 2022 Giant Industries, Inc.