

# Series

# P200-18mm versions

Triplex Ceramic  
Plunger Pump  
Operating Instructions/  
Repair and Service  
Manual



For Models:

P217  
P218  
P219  
P220  
P221  
P227  
P230

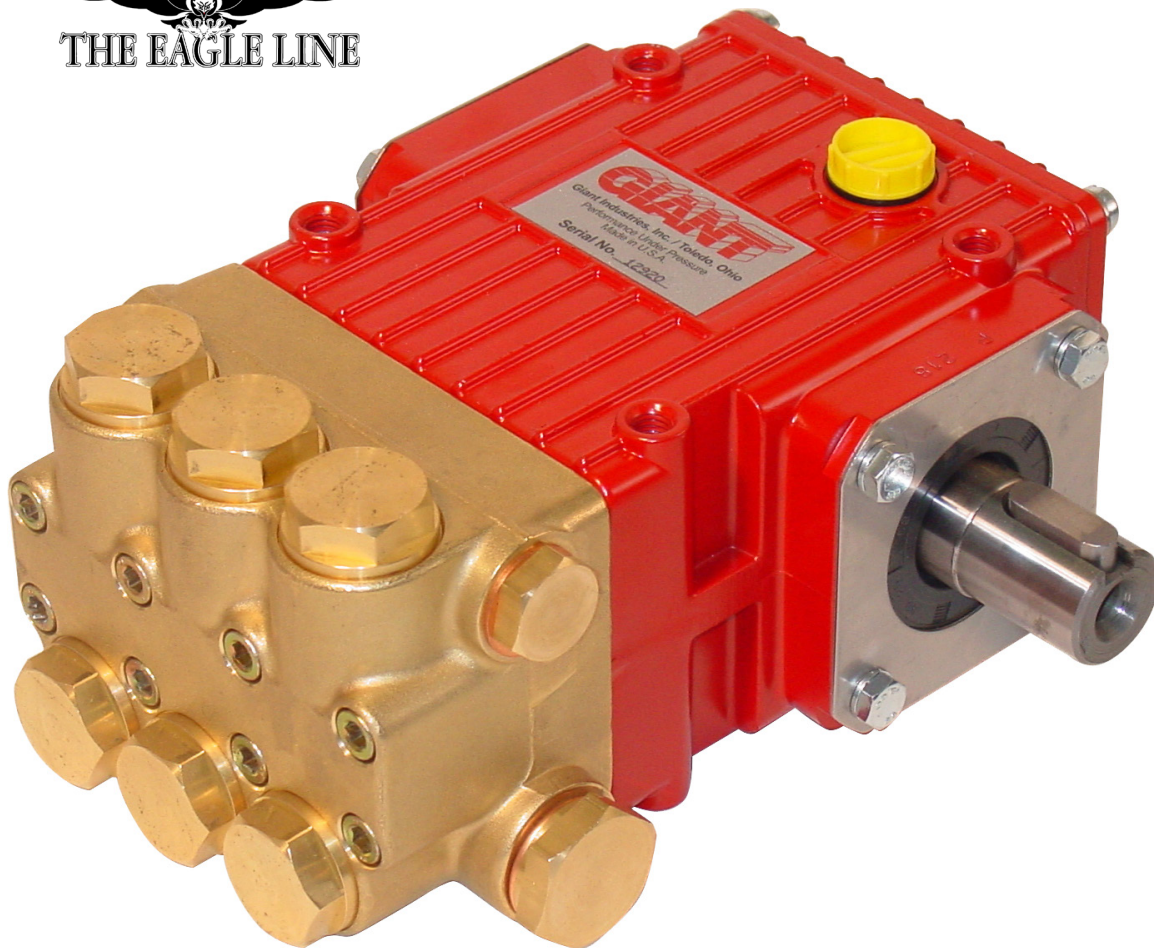

**GIANT**  
Performance Under Pressure

Updated 12/24

<b>Contents:</b>	<b>Page</b>
Installation Instructions:	2
Pump Specifications:	3
Exploded View:	4
Parts List:	5
Repair Kits:	6
Pump System Troubleshooting:	7
Recommended Spare Parts List:	8
Pump Mounting Selection Guide:	8
Torque Specifications:	8
Repair Instructions:	9-10
Dimensions:	11
Warranty Information:	back page

# INSTALLATION INSTRUCTIONS

Required NPSH refers to water: specific weight 1kg/dm<sup>3</sup>, viscosity 1°E at maximum permissible revolutions.

## Operation and Maintenance

Check oil level prior to starting and ensure a trouble-free water supply.

Important! If there is a **danger of frost**, the water in the pump and in the pump fittings (particularly the unloader valve) must be emptied. The second discharge port can also be used and the pump run "dry" for 1-2 minutes for this purpose.

Oil: Use only SAE 20W-50 (p/n 01153). Use 7.5 fluid ounces (0.22 L) for short crankcase covers and 9.0 fluid ounces (0.27 L) for extended crankcase covers.

Initial change after 50 operating hours and then every 500 operating hours, after 1 year if used less.

Caution when operating in damp places or with high temperature fluctuations. Oil must be changed immediately, should condensate (frothy oil) occur in the gear box.

### Keep NPSH under control.

Maximum input pressure 145 PSI (10 bar), maximum suction head -4.35 PSI (-0.3 bar). Make sure suction pulsation is sufficiently dampened - water column resonance must be avoided.

## Safety Rules

Pump operation without safety valve as well as any excess in temperature or speed limits, automatically voids the warranty. The safety valve must be regulated in accordance with the guidelines for liquid spraying units so that the maximum admissible operating pressure can not be exceeded by more than 10%.

When the pump is in operation, the drive shaft end and the coupling must be covered up by either a contact-protector or by a coupling bell.

Pressure in discharge line and in pump must be at zero before any maintenance to the pump takes place. Close up suction line. Disconnect fuses to ensure that the driving motor does not get switched on accidentally.

Make sure that all parts on the pressure side of the unit are vented before starting the pump. In order to prevent air, or an air-water mixture being absorbed and to prevent cavitation occurring, the pump NPSHR suction head and water temperature must be kept under control.

**Cavitation and/or compression of gases lead to uncontrollable pressure kicks which can ruin pump and unit parts and also be dangerous to the operator or anyone standing nearby.**

Giant Plunger Pumps are suitable for pumping clean water and other non-aggressive or abrasive media with a specific weight similar to water.

**Before pumping other liquids - especially inflammable, explosive and toxic media - the pump manufacturer must under all circumstances be consulted with regard to the resistance of the pump material. It is the responsibility of the equipment manufacturer and/or operator to ensure that all pertinent safety regulations are adhered to.**

# Pump Specifications

	Max. Flow	Max. Flow	Nominal/ Intermittent Pressure	Nominal/ Intermittent Pressure	Max. Speed	Max. Inlet Pressure	Max. Inlet Pressure	Plunger Diameter	Plunger Diameter	Stroke	Stroke	Power Req'd	Power Req'd
Model	GPM	l/min	PSI	bar	RPM	PSI	bar	in	mm	in	mm	BHP	kW
P230	1.1	4.2	2000/2500	140/170	1750	145	10	0.71	18	0.13	3.4	1.5/1.9	1.1/1.4
P217	1.8	6.8	2000/2500	140/170	1750	145	10	0.71	18	0.22	5.5	2.5/3.1	1.9/2.3
P230	2.1	7.6	2000/2500	140/170	3450*	145	10	0.71	18	0.13	3.4	2.8/3.5	2.1/2.6
P227	2.1	8.0	2000/2500	140/170	1750	145	10	0.71	18	0.25	6.3	2.9/3.6	2.2/2.7
P221	2.3	8.9	2000/2500	140/170	1750	145	10	0.71	18	0.28	7.0	3.2/4.0	2.4/3.0
P217	3.3	12.5	2000/2500	140/170	3450*	145	10	0.71	18	0.22	5.5	4.6/5.7	3.4/4.3
P218	3.4	12.9	2000/2500	140/170	1750	145	10	0.71	18	0.39	10.0	4.7/5.9	3.5/4.4
P227	3.8	14.4	2000/2500	140/170	3450*	145	10	0.71	18	0.25	6.3	5.2/6.6	3.9/4.9
P219	4.2	15.9	2000/2500	140/170	1750	145	10	0.71	18	0.49	12.4	5.8/7.2	4.3/5.4
P221	4.2	15.9	2000/2500	140/170	3450*	145	10	0.71	18	0.28	7.0	5.8/7.2	4.3/5.4
P220	4.7	17.8	2000/2500	140/170	1750	145	10	0.71	18	0.56	14.1	6.5/8.1	4.8/6.0

\*Positive inlet pressure required- Make sure that suction pulsation is sufficiently dampened-water column resonance must be avoided.

## Common Specifications

	<u>U.S.</u>	<u>Metric</u>
Max. Temperature of Pumped Fluids.....	160° F**	70° C**
Inlet Ports .....		(2) 1/2" BSP
Discharge Ports .....		(2) 3/8" BSP
Shaft Rotation .....		Top of Pulley Towards Fluid End
Crankshaft Diameter.....	0.98"	24 mm
Key Width .....	0.31"	8 mm
Shaft Mounting .....		Either Side
Weight .....	11.7 lbs.	5.3 Kg
Crankcase Oil Capacity.....	7.5 fl.oz.	0.22 Liter
Extended Crankcase Oil Capacity.....	9.0 fl.oz.	0.27 Liter
Volumetric Efficiency @ 1750 RPM.....		0.94
Volumetric Efficiency @ 3450 RPM.....		0.87
Mechanical Efficiency @ 3450 RPM .....		0.86

\*\*For P200-HK pump the rating is 195° F (90° C) . Max. Pressure = 2000 PSI (140 bar)

Consult the factory for special requirements that must be met if the pump is to operate beyond one or more of the limits specified above.

### NOTE:

In order to drive the pump from the side opposite the present shaft extension, simply remove the valve casing from the crankcase and rotate the pumps 180 degrees to the desired position. Be certain to rotate the seal case (item #20) as well, so that the weep holes are down at the six o'clock position. Exchange the oil fill and the oil drain plugs, also. Refer to the repair instructions as necessary for the proper assembly sequence.

### Horsepower Ratings:

We recommend a 1.15 service factor be specified when selecting an electric motor as the power source. To compute electric motor horsepower required, use the following formula:  $HP = (GPM \times PSI) / 1450$ . The formula to determine the horsepower required for a gas engine is:  $HP = (GPM \times PSI) / 1150$ . The formula to determine the horsepower required for a diesel engine is:  $HP = (GPM \times PSI) / 1250$ .

### For the Application of a Hydraulic Motor:

To Determine the Torque of a Hydraulic Motor --  $(GPM \times PSI \times 36.77) / RPM = \text{Torque (in-lbs)}$

### Calculating RPM / GPM of Pump:

A pump must be connected to an electric motor or gas or diesel engine with the correct ratio of pulleys and belts to attain the required speed and GPM. The use of a Variable Frequency Drive (VFD) may also be used to control the RPM of a properly sized electric motor when variable flows are required.

$$(\text{Max. Pump RPM} / \text{Rated Pump GPM}) \times \text{Required Pump GPM} = \text{Required Pump RPM}$$

To calculate a pulley diameter one (1) pulley diameter and the required pump RPM must be known:

$$\begin{aligned} (\text{Pump RPM} \times \text{Pump Pulley Diameter}) / \text{Motor RPM} &= \text{Motor Pulley Diameter} \\ (\text{Motor RPM} \times \text{Motor Pulley Diameter}) / \text{Pump RPM} &= \text{Pump Pulley Diameter} \end{aligned}$$

# Exploded View P217/P218/P219/P220/P221/P227/P230

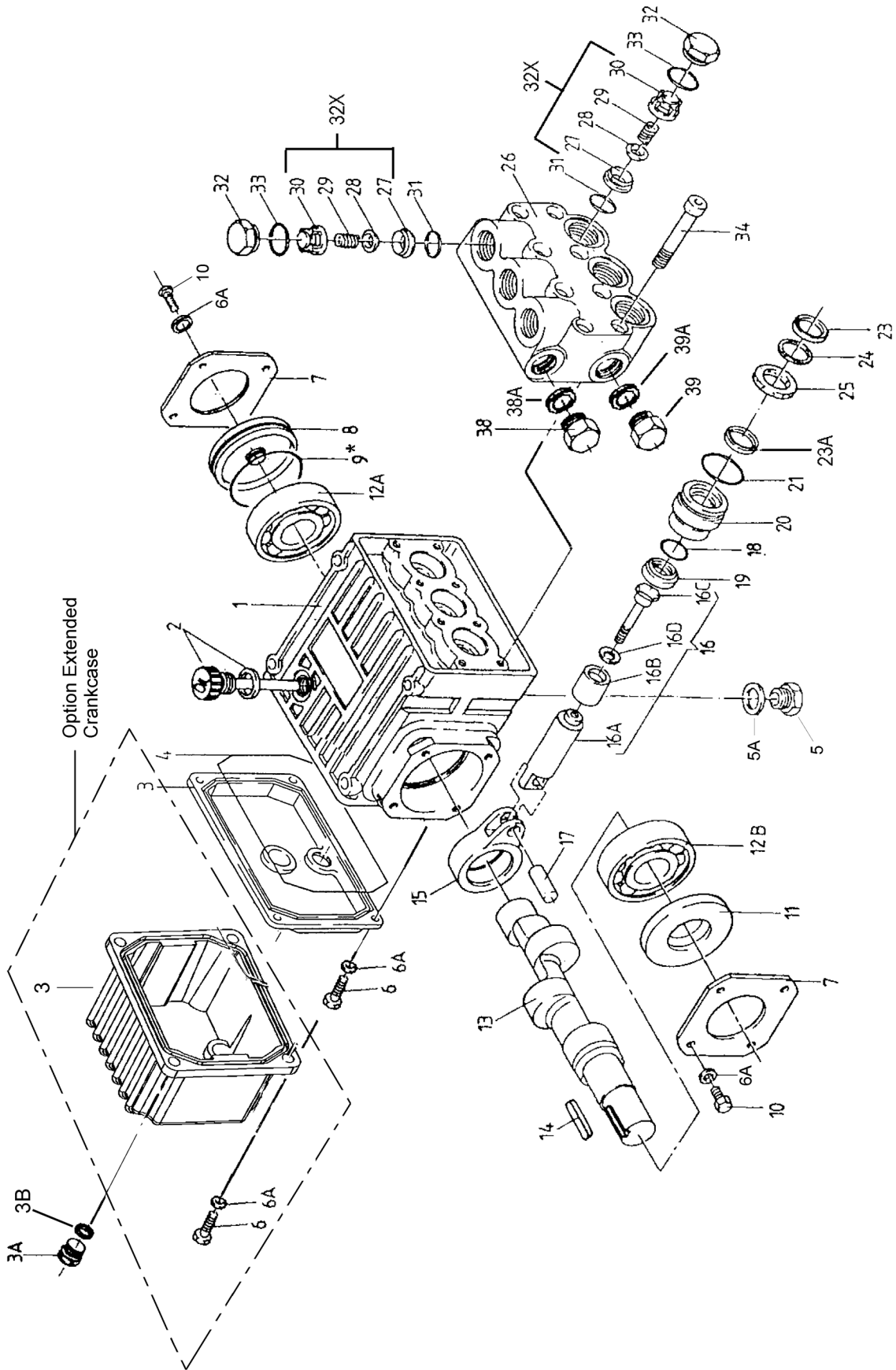

# Spare Parts

## P217/P218/P219/P220/P221/P227/P230

A= P217      B=P218      C=P219      D=P220      E=P221      F=P227      G=P230

<u>ITEM</u>	<u>PART NO.</u>	<u>DESCRIPTION</u>	<u>QTY.</u>	<u>ITEM</u>	<u>PART NO.</u>	<u>DESCRIPTION</u>	<u>QTY.</u>
1	08300	Crankcase (except B & E)	1	13	06547	Crankshaft (F)	1
1	08300C	Crankcase (B & E Only)	1	13	06694	Crankshaft (G)	1
2	06773	Oil Dipstick with O-Ring	1	14	06207	Woodruff Key	1
3	08302	Crankcase Cover, Short	1	15	08333	Connecting Rod	3
3	08302-L	Crankcase Cover, Long	1	16	08469	Plunger, Complete, 18mm	3
3A	07190	Drain Plug	1	16A	08468	Plunger Base	3
3B	13262A	Gasket	1	16B	08455	Plunger Pipe	3
4	08005	O-Ring	1	16C	08456	Tension Screw	3
5	06273	Oil Drain Plug	1	16D	07676	Copper Gasket	3
5A	08192	Gasket	1	17	08442	Wrist Pin	3
6	07188	Screw, Crankcase Cover	4	18	07770	O-Ring	3
6A	01176-2	Spring Washer	12	19	08356	Oil Seal	3
7	08303	Bearing Cover I	2	20	08444	Seal Case	3
8	08490	Sight Glass (except B & E)	1	21	08443	O-Ring	3
8	08491	Sight Glass (B & E Only)	1	23	08477	V-Sleeve, Weep	3
9	08492	O-Ring for Sight Glass (except B & E)	1	23A	08087	V-Sleeve, Brown	3
9	07193	O-Ring for Sight Glass (B & E Only)	1	24	07904	Pressure Ring	3
10	07225	Screw with Lock Washer	8	25	08445	Weep Return Ring	3
11	01166	Radial Shaft Seal (except B & E)	1	26	06582 <sup>+</sup>	Valve Casing 1/2" Inlet Ports	1
11	08331	Radial Shaft Seal (B & E Only)	1	27	07849	Valve Seat	6
12A	08020	Ball Bearing (except B & E)	1	28	07491	Valve Plate	6
12A	04917	Ball Bearing (B & E Only)	1	29	07906	Valve Spring	6
12B	01020	Ball Bearing (except B & E)	1	30	07907	Valve Spring Retainer	6
12B	01086	Ball Bearing (B & E Only)	1	31	07853	O-Ring	6
13	08465	Crankshaft (A)	1	32	07928	Valve Plug	6
13	04920	Crankshaft (B)	1	32X	07946A	Valve Assembly Complete	6
13	08466	Crankshaft (C)	1	33	07913	O-Ring	6
13	08467	Crankshaft (D)	1	34	08316	Hex Head Cap Screw	8
13	04922	Crankshaft (E)	1	38	13338	Plug, 3/8" BSP	1
				38A	08486	Copper Crush Washer, 3/8"	1
				39	07109	Plug, 1/2" BSP	1
				39A	07661	Seal	1

# Repair Kits

## P217/P218/P219/P220/P221/P227/P230

### Plunger Packing Kit

#### Part # 09164

<u>Item #</u>	<u>Part #</u>	<u>Description</u>	<u>Qty.</u>
23	08477	V-Sleeve, Weep	3
23A	08087	V-Sleeve, Brown	3
24	07904	Pressure Ring	3

### Valve Assembly Kit

#### Part # 09116

<u>Item #</u>	<u>Part #</u>	<u>Description</u>	<u>Qty.</u>
32X	07946A	Valve Assembly Complete	6
31	07853	O-Ring	6
33	07913	O-Ring	6

### Oil Seal Kit

#### Part # 09144

<u>Item #</u>	<u>Part #</u>	<u>Description</u>	<u>Qty.</u>
19	08356	Oil Seal	3

### Optional Kits

#### Teflon Plunger Packing Kit

##### Part # 09164-0021

<u>Item #</u>	<u>Part #</u>	<u>Description</u>	<u>Qty.</u>
18	07770-0001	O-Ring, Viton	3
21	08443-0001	O-Ring, Viton	3
23/23A	08087-0020	Weep Seal, Teflon	6
24	07904	Pressure Ring	3
31	07853-0001	O-Ring, Viton	6
33	07913-0001	O-Ring, Viton	6

#### Viton Seal Kit

##### # 09164-0011

<u>Item</u>	<u>Part #</u>	<u>Description</u>	<u>Qty.</u>
18	07770-0001	O-Ring, Viton	3
21	08443-0001	O-Ring, Viton	3
23	08087-0010	V-Sleeve	6
24	07904	Pressure Ring	3
31	07853-0001	O-Ring, Viton	6
33	07913-0001	O-Ring, Viton	6

#### High Temperature Seal Kit

##### # 09599

<u>Item</u>	<u>Part #</u>	<u>Description</u>	<u>Qty.</u>
23/23A	08477-0030	High-Temp Seal	6
24	07904	Pressure Ring	6+

+ Kit contains six (6) pressure rings. Only three (3) are required for the P200 Series Pumps.

# PUMP SYSTEM MALFUNCTION

<u>MALFUNCTION</u>	<u>CAUSE</u>	<u>REMEDY</u>
The Pressure and/ or the Delivery Drops	Worn packing seals Broken valve spring Belt slippage Worn or Damaged nozzle Fouled discharge valve Fouled inlet strainer Worn or Damaged hose Worn or Plugged relief valve on pump Cavitation  Unloader	Replace packing seals Replace spring Tighten or Replace belt Replace nozzle Clean valve assembly Clean strainer Repair/Replace hose Clean, Reset, and Replace worn parts Check suction lines on inlet of pump for restrictions Check for proper operation
Water in crankcase	High humidity Worn seals	Reduce oil change interval Replace seals
Noisy Operation	Worn bearings  Cavitation	Replace bearings, Refill crankcase oil with recommended lubricant Check inlet lines for restrictions and/or proper sizing
Rough/Pulsating Operation with sure Drop	Worn packing Inlet restriction  Accumulator pressure Unloader Cavitation	Replace packing Check system for stoppage, air Pres- leaks, correctly sized inlet plumbing to pump Recharge/Replace accumulator Check for proper operation Check inlet lines for restrictions and/or proper size
Pump Pressure as Rated, Pressure Drop at gun	Restricted discharge plumbing	Re-size discharge plumbing to flow rate of pump
Excessive Leakage	Worn plungers Worn packing/seals Excessive vacuum Cracked plungers Inlet pressure too high	Replace plungers Adjust or Replace packing seals Reduce suction vacuum Replace plungers Reduce inlet pressure
High Crankcase Temperature	Wrong Grade of oil Improper amount of oil in crankcase	Giant oil is recommended Adjust oil level to proper amount

# Preventative Maintenance Check List & Recommended Spare Parts List

Check	Daily	Weekly	50 Hrs.	Every 500 Hrs	Every 1500 Hrs	Every 3000 Hrs
Oil Level/Quality	X					
Oil Leaks	X					
Water Leaks	X					
Belts, Puelly		X				
Plumbing		X				
<b>Recommended Spare Parts</b>						
Oil Change (1 quart) p/n 01153			X	X		
Plunger Seal Kit (1 kit/pump)					X	
Oil Seal Kit (1 kit/pump)					X	
Valve Assembly Kit (1 kit/pump)						X

## Pump Mounting Selection Guide

<b>Bushings</b> <b>01074</b> - 24 mm Tapered H Bushing
<b>Pulley &amp; Sheaves</b> <b>01061</b> - 7.75" Cast Iron 1 gr. AB Section <b>01062</b> - 7.75" Cast Iron - 2 gr. AB Section
<b>Rails</b> <b>01160</b> - Plated Steel Channel Rails (L=5.75"x W=1.00"x h=2.50") <b>01161</b> - Plated Steel Channel Rails (L=5.75"x W=1.00"x H=2.50")

## Torque Specifications

<u>Item</u>	<u>Part No.</u>	<u>Description</u>	<u>Lubrication</u>	<u>Torque Amount</u>
3A	07190	Drain Plug		22 ft.-lbs. (30 Nm)
5	06273	Oil Drain Plug w/Gasket		22 ft.-lbs. (30 Nm)
6	07188	Screw, Short Cover		88 in.-lbs. (10 Nm)
10	07225	Screw w/Lock Washer		88 in.-lbs. (10 Nm)
16C	08456	Tension Screw	Loctite 243	200 in.-lbs. (22.5 Nm)
16D	07676	Copper Gasket	Loctite 243	N/A
32	07928	Valve Plug	Loctite 243	55 ft.-lbs. (75 Nm)
34	08316	Hex Head Cap Screw		106 in.-lbs. (12 Nm)



## REPAIR INSTRUCTIONS - P217/P218/P219/P220/P221/P227/P230 PUMPS

**NOTE:** Always take time to lubricate all metal and nonmetal parts with a light film of oil before reassembly. This step will ensure proper fit, at the same time protecting the pump nonmetal parts (i.e., the elastomers) from cutting and scoring.



1. With a 22mm socket wrench, remove the (3) discharge valve plugs and (3) inlet valve plugs (32) Inspect the o-ring (33) for wear and replace if damaged.

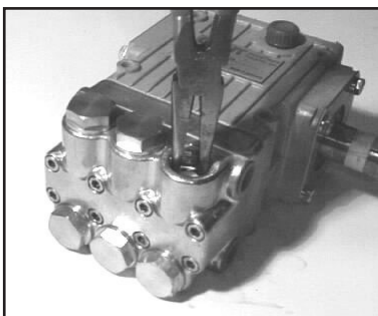

2. Using a needle nose pliers, remove the inlet and discharge valve assemblies (32X).

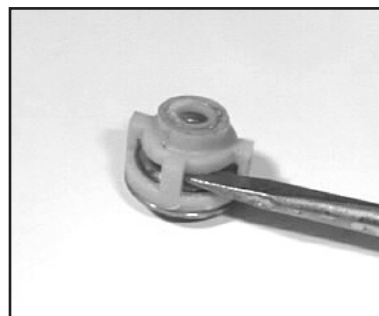

3. By inserting a small screw driver between the valve seat (27) and the valve spring retainer (30), the valve assembly can be separated.

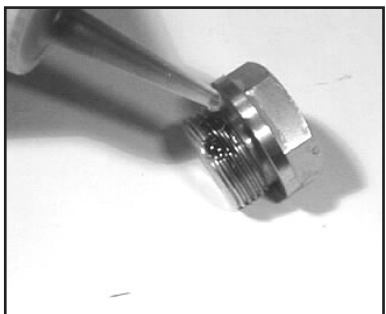

4. Remove the o-ring (31). Inspect all parts for wear and replace as necessary. Apply one drop of Loctite 243 to the valve plugs (32) and tighten to 55 ft.-lbs. (75 Nm)

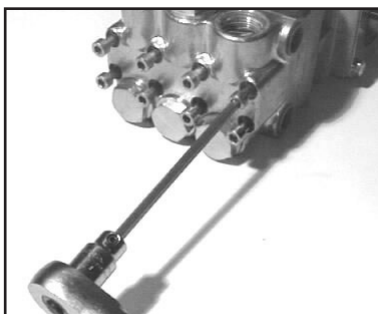

5. Next, use a 5mm allen wrench to remove the 8 socket head cap screws (34).

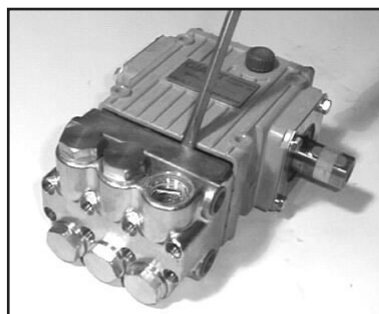

6. Carefully slide the valve casing (26) out over the plungers.



7. Remove the weep return ring (25), pressure ring (24), and v-sleeve (23) from the valve casing (26). Remove the v-sleeve (23A) from the seal case (20). Inspect all parts, including o-ring (21) for wear and replace as necessary

8. Check surfaces of plunger (16). A damaged surface will cause accelerated wear on the seals. Deposits of any kind must be carefully removed from the plunger surface. A damaged plunger must be replaced!

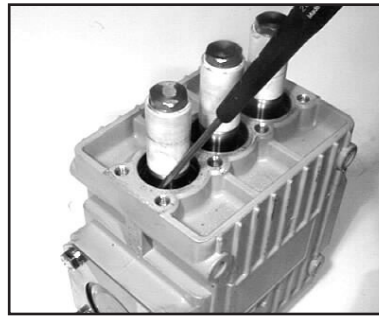

9. If the crankcase oil seals (19) are to be replaced, they can be removed by prying loose with a flat screwdriver. Take care not to make contact with the plunger.

## REPAIR INSTRUCTIONS - P217/P218/P219/P220/P221/P227/P230 PUMPS

10. If the ceramic plunger pipe (16B) is damaged, remove the plunger bolt (16C). Discard the old plunger pipe (16B) and copper gasket (16D), and clean the old lock-tite from the plunger bolt (16C) and plunger base (16A). Replace the plunger with the new one and locktite the plunger bolt and torque to 200 in.-lbs. (22.5 Nm)

***NOTE: If there are deposits of any kind (i.e., lime deposits) in the valve casing, be certain that the weep holes in the weep return ring (25) and valve casing (26) have not been plugged.***

### Reassembly sequence of the P217/P218/P219/P220/P221/P227/P230 pumps

- 1) If oil seals (19) were removed, replace with seal lip towards crankcase. Lubricate seals before replacing.
- 2) Replace seal case (20) with o-rings (21) over plungers. Generously lubricate o-rings and oil seal before reassembly. Replace v-sleeve (23A) over plungers (16)..
- 3) Generously lubricate v-sleeve (23). Assemble v-sleeves (22) into valve casing (#26). Assemble weep return ring (25) and pressure ring (24) over plungers (16). Slide valve casing over plungers and seat firmly. Replace the eight socket head cap screws (34) and tighten to 106 inch-pounds (12 Nm) in a crossing pattern.
- 4) Replace the six o-rings (31) and the six valve assemblies (32X). Now replace the six valve plug o-rings (33). For pumps manufactured prior to 5/97, tighten plugs (32) to 33 ft.-lbs. otherwise, apply one drop of Loctite 243 to the valve plugs (32) and tighten to 55 ft.-lbs. (75 Nm).

**NOTE: Contact Giant Industries for Service School Information. Phone: (419)-531-4600**

**Dimensions - Inches (mm)**  
**P217/P218/P219/P220/P221/P227/P230**

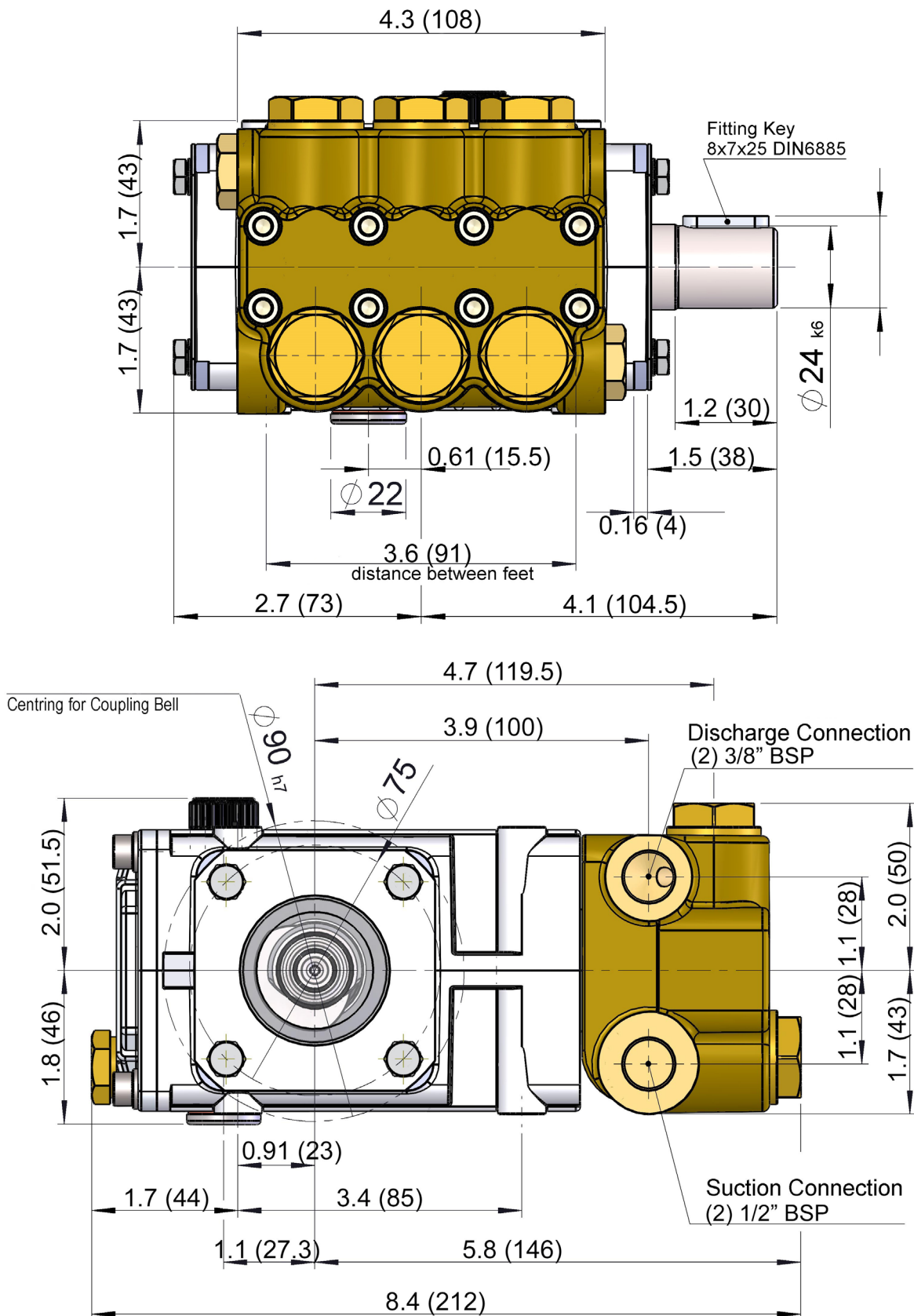

## GIANT INDUSTRIES LIMITED WARRANTY

Giant Industries, Inc. pumps and accessories are warranted by the manufacturer to be free from defects in workmanship and material as follows:

1. Five (5) years from the date of shipment for all pumps used in portable pressure washers with NON-SALINE, clean water applications.
2. Two (2) years from the date of shipment for Giant pumps used in car wash applications.
3. One (1) year from the date of shipment for all other Giant industrial and consumer pumps.
4. Six (6) months from the date of shipment for all rebuilt pumps
5. Ninety (90) days from the date of shipment for all Giant accessories.

This warranty is limited to repair or replacement of pumps and accessories of which the manufacturer's evaluation shows were defective at the time of shipment by the manufacturer. The following items are NOT covered or will void the warranty:

1. Defects caused by negligence or fault of the buyer or third party.
2. Normal wear and tear to standard wear parts.
3. Use of repair parts other than those manufactured or authorized by Giant.
4. Improper use of the product as a component part.
5. Changes or modifications made by the customer or third party.
6. The operation of pumps and or accessories exceeding the specifications set forth in the Operations Manuals provided by Giant Industries, Inc.

Liability under this warranty is on all non-wear parts and limited to the replacement or repair of those products returned freight prepaid to Giant Industries which are deemed to be defective due to workmanship or failure of material. A Returned Goods Authorization (R.G.A.) number and completed warranty evaluation form is required prior to the return to Giant Industries of all products under warranty consideration. Call (419)-531-4600 or fax (419)-531-6836 to obtain an R.G.A. number.

Repair or replacement of defective products as provided is the sole and exclusive remedy provided hereunder and the MANUFACTURER SHALL NOT BE LIABLE FOR FURTHER LOSS, DAMAGES, OR EXPENSES, INCLUDING INCIDENTAL AND CONSEQUENTIAL DAMAGES DIRECTLY OR INDIRECTLY ARISING FROM THE SALE OR USE OF THIS PRODUCT.

THE LIMITED WARRANTY SET FORTH HEREIN IS IN LIEU OF ALL OTHER WARRANTIES OR REPRESENTATION, EXPRESS OR IMPLIED, INCLUDING WITHOUT LIMITATION ANY WARRANTIES OR MERCHANTABILITY OR FITNESS FOR A PARTICULAR PURPOSE AND ALL SUCH WARRANTIES ARE HEREBY DISCLAIMED AND EXCLUDED BY THE MANUFACTURER.



**WARNING:** This product might contain a chemical known to the State of California to cause cancer, and birth defects or other reproductive harm.  
For more information go to [www.P65Warnings.ca.gov](http://www.P65Warnings.ca.gov)



**GIANT INDUSTRIES, INC.** 900 N. Westwood Ave., Toledo, Ohio 43607  
Phone: (419)-531-4600 FAX (419)-531-6836, [www.giantpumps.com](http://www.giantpumps.com)  
© Copyright 2024 Giant Industries, Inc.